

Introduction to concrete blocks

What you will learn

When you have finished this module you should be able to:

- Say what types of blocks you can make or buy.
- Know some of the good and bad things about different blocks.
- Choose the right blocks for a job.



Things you need before you start

Materials

None



Tools or equipment

None



Course resources

Course video



Video player



What is a concrete block?

Concrete blocks can be in all sorts of shapes and sizes.

Some are solid

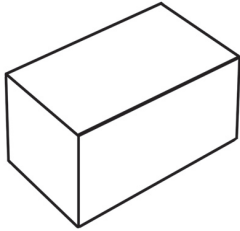

Most are hollow

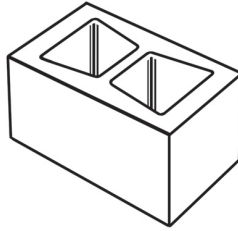

Here are some examples.

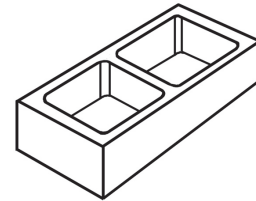
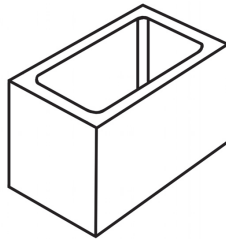
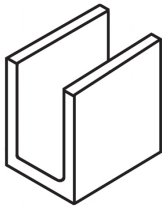

In some countries they are called “bricks”. Their proper name is a “concrete masonry unit”.

In this course, we will call them **blocks**.

Here are the names for parts of a block

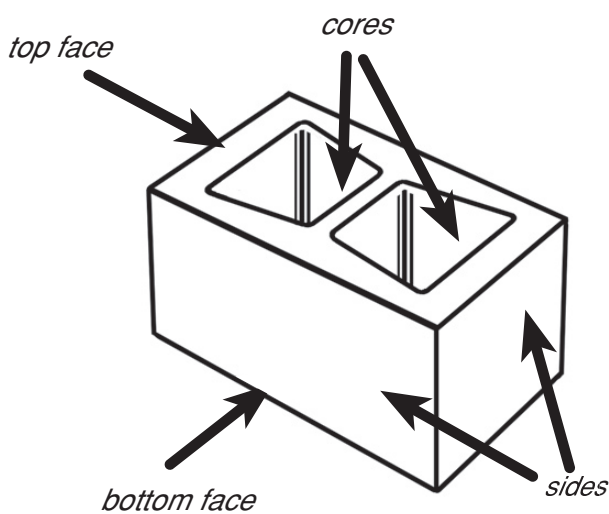

*tapered cores
(narrow at top)*

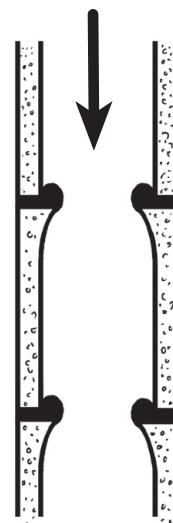

The hollow cores in most blocks are smaller at the top — so the top face of the block has wider edges.

Blocks are joined together with a wet paste called *mortar*.

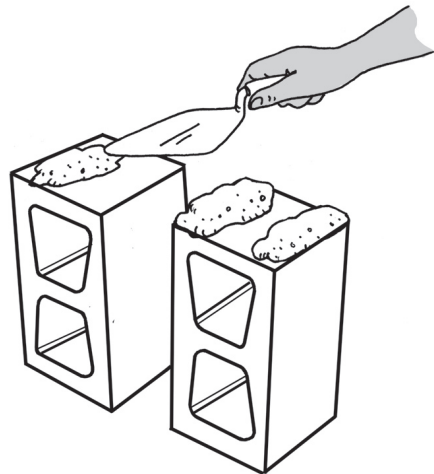
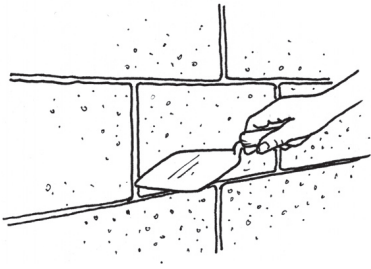

Some places call this paste “cement”.

In this course we will call it *mortar* and use the name ‘cement’ for the grey powder used to make both concrete and mortar.

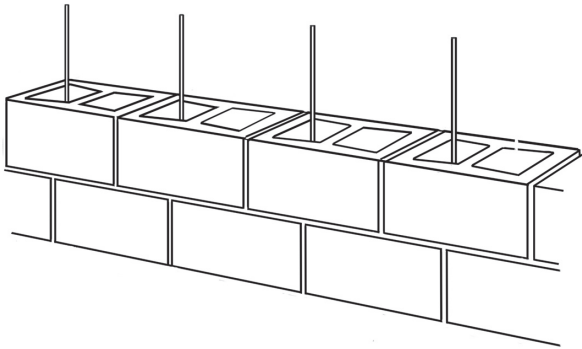

The hollow blocks in a wall can be filled with concrete or steel reinforcing rods to make them stronger.

What are blocks used for?

They can be used to:



Make walls



Build houses



Make steps



Support water tanks

Activity

What are blocks used for in the area where you live?

Write down or draw five things



Good things about blocks



Blocks are:

- strong
- quick to work with
- not attacked by rot and insects
- last a long time

Any others ?



But . . .

Blocks are heavy

\$ \$ \$

Blocks cost money!

Where do our blocks come from?

Concrete blocks can be made in big numbers by a machine.



Or they can be made in moulds by hand



Left: new blocks are laid out to harden and sprayed with water to cure.

Look at:

The video to see a block making machine working in Tarawa, Kiribati and how blocks are made by hand in Vanuatu.

Activity

Work with your friends and other students. Find out the answers to these questions:

Where do the blocks we use come from?

Near where we live?

Fiji?

Australia?

New Zealand?

Somewhere else?

Where?

Where do we buy them from?

Can we make our own?

.....

Types of blocks

Concrete blocks can be made in lots of shapes and sizes.

In big towns a block making plant may make many different types, but in most places you can only buy, or make, one or two types of block.

Here are some examples

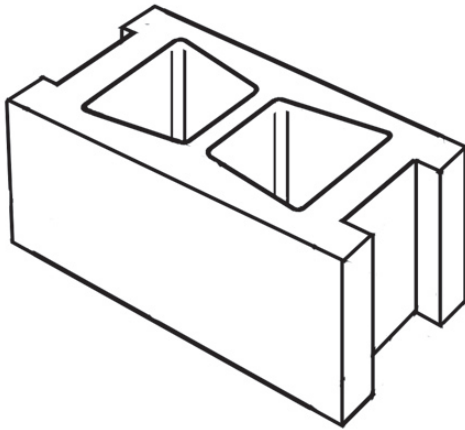

A standard hollow block with shaped end faces
Some people call it a '*stretcher*'

A standard hollow block with **flat** end faces

Also called '*stretcher*'

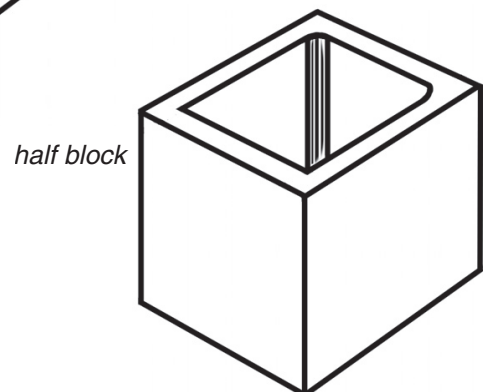
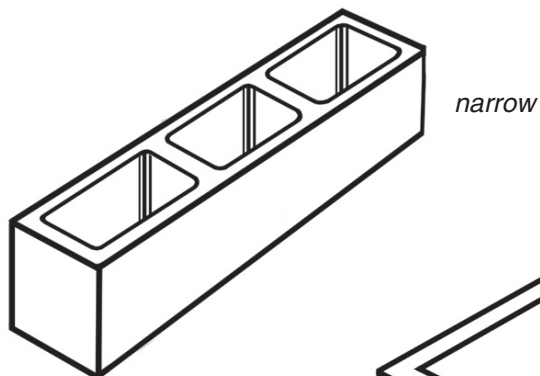
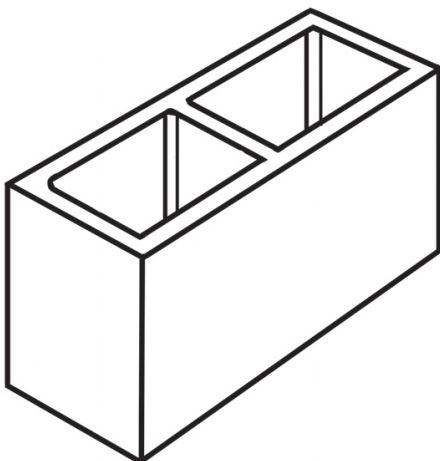

Sizes

Standard sizes

Most standard blocks are 400 mm long and 200mm high

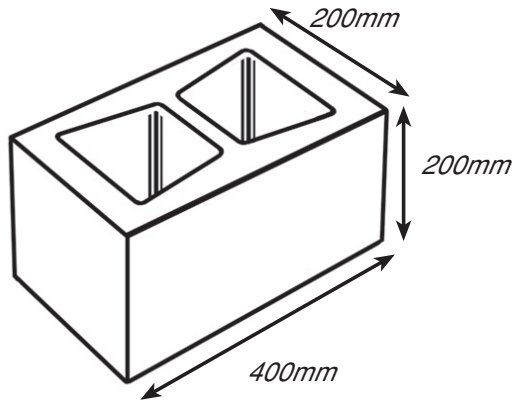

The most common width is also 200mm — but blocks that are 150mm and 250mm wide are sometimes made.

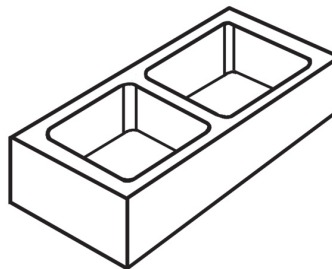
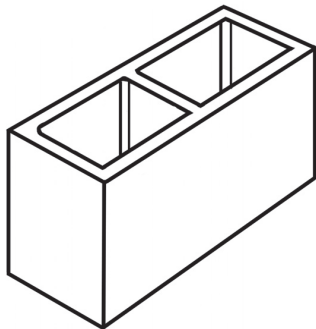

Note on 'nominal' sizes

All these sizes shown above are *nominal* sizes. They are the sizes you will see shown at the store, or talked about by the people who work there.

“Nominal” is a term used by most trades people to mean “*about this size*” or “*it will be this size when it is finished*”.

The *actual* sizes of concrete blocks are usually 10mm smaller than the *nominal*.

So a standard block is actually 190mm x 190mm x 390mm — like this

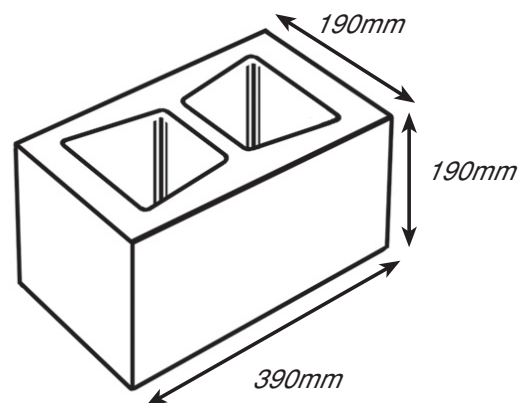

This allows for 10mm of mortar in each joint to bring the size back to 200 x 200 x 400.

Half sizes

These blocks are the same height and width as standard blocks — but only half as long.

If they are available, half-blocks are very useful for ends of walls. You don't have to cut standard blocks to fit.

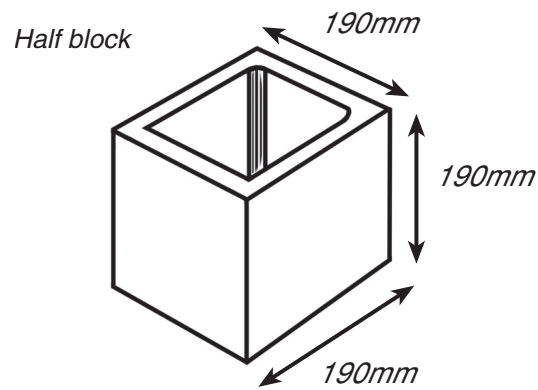

In the next module you will see how to fit blocks together and how to choose the blocks you need.

Activity

Work with others on this activity.

What types and sizes of blocks can you buy, or make, where you live?

Write them down — or draw them.

How much do they cost?

How can you get them to the place where you want to build?

.....

Bad blocks



When you buy blocks, watch out for these sort of faults:

Don't buy them if you can help it!

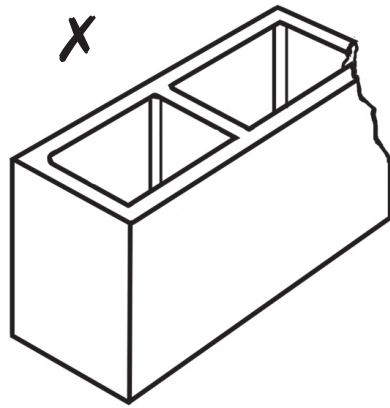
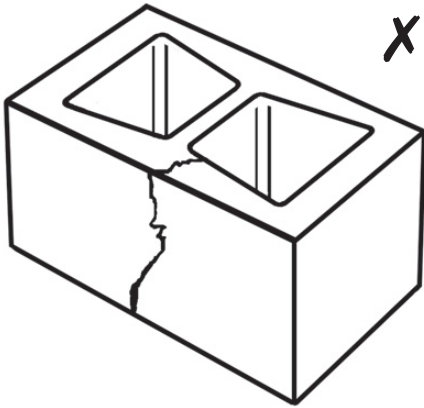

Steps in building with blocks

When you make a wall or other construction with blocks you do each of these steps:

1. Plan and design

work out how the wall goes together and the amounts you need

2. Make foundations

to support the wall

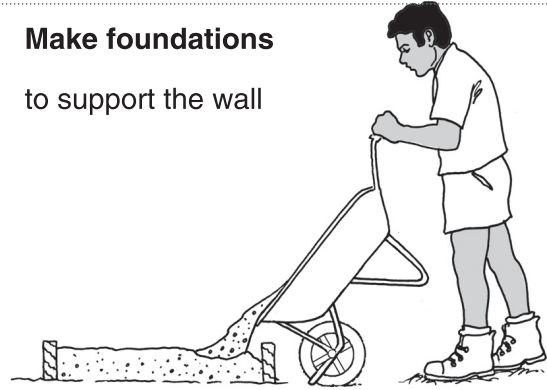

3. Collect materials and tools

get everything you need

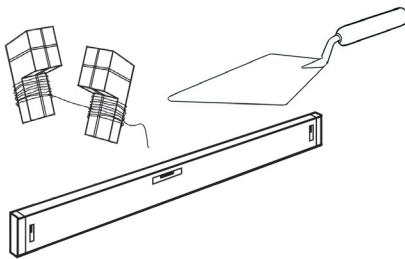

4. Mix mortar

ready to lay blocks



5. Lay blocks level and straight

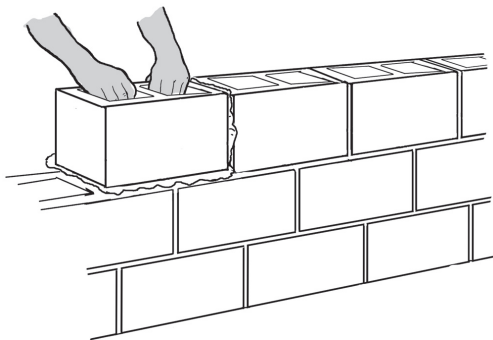

6. Finish

joints and surfaces

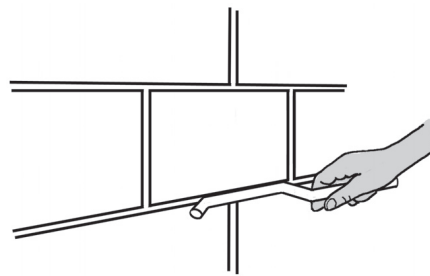

7. Fill cores

around any reinforcing

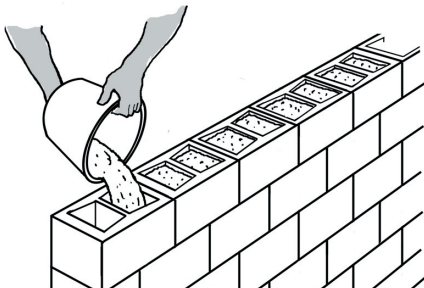

8. Clean up

tools and all around the work area