

# Fuel

## What you will learn

When you have finished this module, you should be able to:

- Choose the right fuel for the engine
- Mix the right petrol and oil for a 2-stroke engine
- Know the main parts of a fuel system
- Check fuel tanks, lines and primers
- Check and replace fuel filters
- Know about safety with fuel



## Things you need before you start

### Materials

Paper and pencil

Engine, filters and fuel tank

---

### Tools

Containers for mixing fuel

Screwdrivers, spanners and pliers

---

# Types of fuel

All engines need fuel of some sort to mix with air and then burn (explode!) inside the cylinder.

You may come across these fuels:

Petrol

Petroil mix

Diesel

Kerosene

We'll look at each of them.

## Petrol

In some places, petrol is called 'gas', gasoline, essence. You may have your own name.

Petrol is the most common fuel used for cars, motor bikes and small engines.

Petrol is used by itself in 4-stroke engines, and is mixed with oil for use in most 2-stroke engines (see petroil below)

### **Safety note**

**The fumes from petrol ignite (catch fire) very easily. That makes it a good fuel to use in the engine, but it makes it very dangerous.**

**Leaking petrol- or petrol fumes can explode. You must be very careful around petrol!**

**Never have flames (or cigarettes) or make sparks near petrol.**

Petrol is made in different ‘grades’ that burn faster or slower in the engine to produce different amounts of power/energy. Common names are ‘Regular’ and the more powerful ‘Super’ or ‘Premium’ grades.

The amount of energy in the petrol is given by its ‘Octane rating’ (called ‘RON’s in some places).

In New Zealand and Australia ‘Regular’ grade is 91 octane and ‘Premium’ is 95 octane.

Your local petrol may have a higher or lower Octane/ RON rating than this.



Your engine will work best with a fuel that is close to the manufacturers recommended Octane grade. It may be written on or near the fuel filler – or in the technical manual that came with the engine.

Don’t use very low octane fuel in an engine that needs high octane fuel – it can damage it.

## Petrol and oil mix (petroil)

This fuel is a mixture of petrol and a small amount of special oil.

It is used in 2-stroke engines. It’s sometimes called ‘pre-mix’ 2-stroke fuel.

The *petrol* is exactly the same as described above, and the octane rating information also applies.

The *oil* is a special 2-stroke oil. It lubricates all the moving metal parts of the engine, so it is very important that:

- the oil is the right type
- there is the right amount of oil in the mix.

## Type of 2-stroke oil

Use a 2-stroke oil that is made for the job.

Most big oil companies make a good 2-stroke oil.

For outboard motors, most engine makers recommend an oil with a standards rating of ‘TCW3’. Look for this rating on the container.

**Never** use ordinary engine oil.



## Amounts of fuel and oil

Different 2-stroke engines need different amounts of oil mixed in the fuel. This is called the *ratio* of oil to fuel.

The recommended ratio depends on the design of the engine, and what the engine is used for.

The ratio is usually written like this: 50 : 1

That means 50 parts of petrol and 1 part of oil

So, that could be 50 litres of petrol - to - 1 litre of oil

Or 25 lt - to - 0.5 lt (half litre, or 500ml)

Or 10 lt - to - 0.20lt (200ml)

Or 1 lt - to - 0.020lt (20ml)



Use the ratio recommended by your manufacturer. It is often written on the engine – on or near the fuel cap.



Some common petrol/oil ratios are:

Ratio	Amount of oil to mix with petrol		
	1 litre petrol	10 litres petrol	25 litres petrol
25 : 1	40ml	400ml	1 litre
40 : 1	25ml	250ml	625ml
50 : 1	20ml	200ml	0.5 litre (500ml)
75 : 1	14ml	140ml	350ml

Measure the amounts carefully.

## Mixing

Petrol must be thoroughly mixed to make sure the oil coats the engine parts properly.

1. put about half the petrol into your container.
2. add the right amount of 2-stroke oil
3. fit the fuel cap, then shake the container to mix the fuel
4. add the rest of the petrol, fit the cap and shake again.

Always shake the container again before using the fuel.

### Important things about your fuel

Fuel must be

- ***Clean.*** Dirt, dust and sand will block fuel jets (small holes) and damage an engine. There should be a fuel filter in the fuel tank – or on the engine- to remove dirt in the fuel – but it is best not to use dirty fuel. For example, avoid using the last fuel from the bottom of a large drum.
- ***Dry.*** Water in the fuel will block filters and jets and can damage the engine. Some fuel systems have special water traps in the fuel lines and these need to be checked and cleaned. Never use any fuel that looks as if it has drops of water in it.
- ***Fresh.*** ‘Old’ fuel goes ‘bad’ over a few months. It can make engines difficult to start and can leave gummy deposits in the engine. Always use fresh fuel if you can. Empty your fuel tank if you are not going to use an engine in the next 2 months.

## Other Fuels

These two fuels are not covered in this course:

### Diesel

This is a heavier, oily fuel used in large engines such as trucks, large boats or ships, big generators. Diesel is ignited in the engine by a very high compression instead of using a spark plug. Diesel fuel will not run in a petrol engine.

*Bio-diesel* is becoming available in some places. It is an oil made from plant material – such as coconut – and added to normal diesel fuel oil.

### Paraffin/kerosene

This is used for cleaning, heating and lighting. It is also used in aircraft jet engines, but kerosene will not work as a fuel in small engines.

# Fuel Filters

A fuel filter will catch dirt in the fuel before it gets into the engine.

There will be at least one filter in your system – or more. Filters can be inside the fuel tank, in the fuel line or where the fuel goes into the carburettor/injection system.

There are many types of filter – some can be cleaned and others are sealed units that you have to replace. Look under ‘maintenance’ for the different types of filter and how to service them.

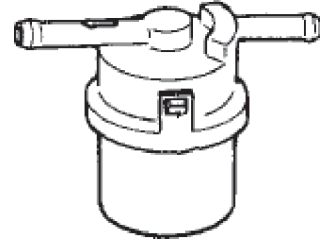

A clogged filter will reduce the fuel flow, causing a drop in engine performance as the engine struggles to draw in enough fuel.

Fuel filters need to be maintained at regular service intervals.

# Carburettor

The carburettor mixes fuel with air at the inlet to the engine.

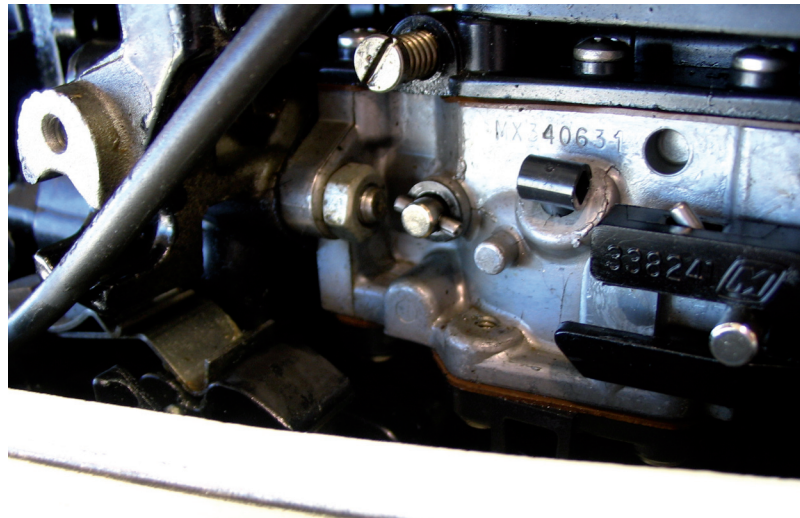

## How do they work?

Fuel comes from the tank into a *fuel bowl* in the carburettor and then goes through small pipes to meet the air. Small *jets* (a tube with a small, but exact-size hole) control the amount of fuel that can flow.

Air comes through the *special shaped tube* through the carburettor. (known as a venturi or choke tube) The special shape makes the air move very fast at the point where it meets the fuel. This mixes the fuel to tiny droplets that then go on into the cylinder.

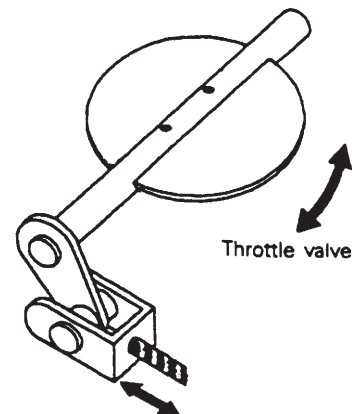
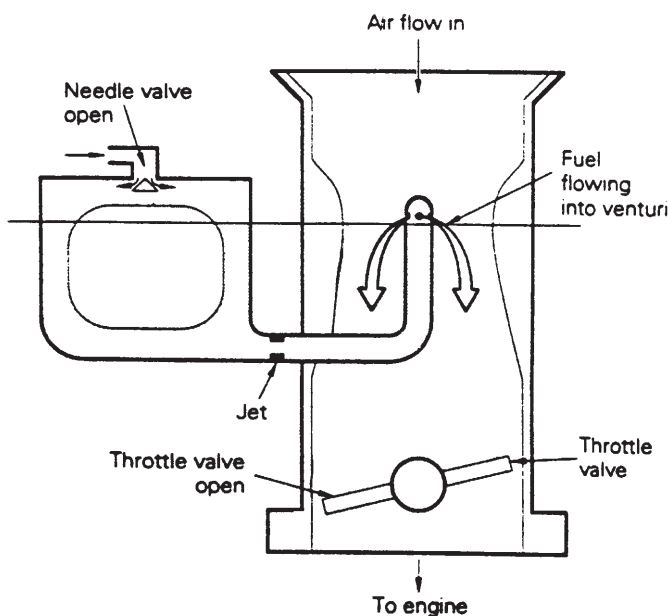
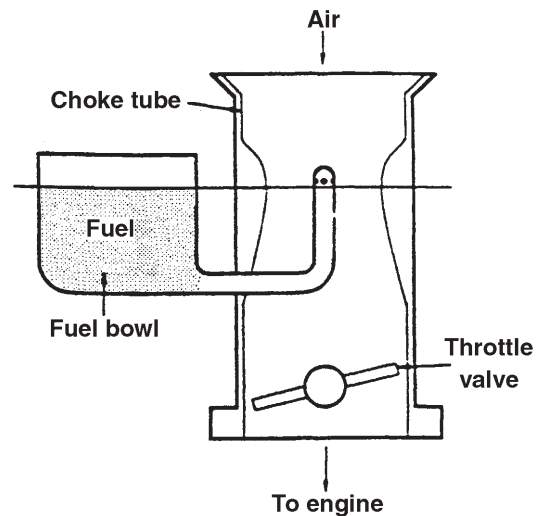



The amount of air is controlled by the *throttle valve* that turns in the tube. You move the valve with the accelerator. The more air you let in, the faster the engine goes.

Real carburetors work the same way as the diagrams, but they have lots more jets, airways and controls to adjust the air/fuel mix for the engine at all speeds and loads, maximum power and maximum economy.

Some carburetors can be adjusted – but it is very easy to upset the fuel-mix to a point where the engine:

- will not start or
- will not run
- has no power
- damages itself through overheating.

It is much more difficult to adjust the settings back again!

Our advice is **not to touch** the carburettor adjustments unless you know what you are doing and have the experience and equipment to set them accurately.

If you think there is something wrong with the fuel adjustments, find an experienced person to help you.



It MAY BE possible to adjust the engine *idle speed* and the *slow running mix* adjustments. The adjustments are different on all carburetors, so only make the adjustments if you have the manufacturers instruction manual to show you how.

# Fuel Tanks

Fuel tanks for small engines are of two main types:

## A small tank mounted on the engine itself

These are used on lawn-mowers, chainsaws, brush-cutters, small generating sets and some low-powered outboard motors.



© tackletour.com

The tank can be almost any shape – often made of moulded plastic to fit the design of the machine. The tanks usually have a filler cap with a vent – to let the air in – and a fuel on/off tap. They usually hold enough fuel for about an hours running (0.5 to 2 litres).

Check fuel tap is “off” when the engine is not in use.

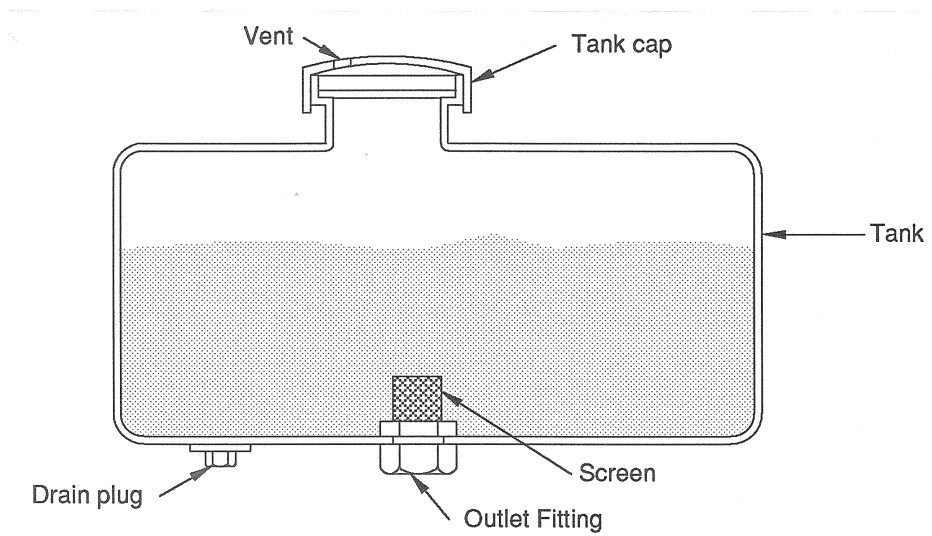



### Separate fuel tanks

Larger capacity tanks (5 – 40 litres) with quick-connect fuel lines.

These tanks are commonly used with outboard motors where several tanks can be used for safety and for longer trips.

For marine use, these tanks are usually made of plastic with rounded corners. They have leak-proof filler caps and an air vent/valve that is opened when the tank is in use. They may also have a built in hand-pump for priming or connections for pressure-feed systems



Check cap and valve/vent are closed when the tank is not in use.

# Fuel lines and pumps

Most small engines with fuel tanks attached to the engine use a 'gravity feed' fuel system with no fuel pump. Other engines have a fuel pump built into the carburettor.

Bigger engines with separate fuel tanks have a pump to get fuel to the engine from the tank. The pump may have a filter that needs to be cleaned.

Separate tanks usually have easily-made line connectors like these.



*Line connections*



Most engines have some sort of **priming pump** to get the first fuel to the engine.

With a remote tank system this is a primer bulb in the fuel line that you squeeze by hand. There could be a pump on the tank itself instead.

*Line primer bulb*



Gravity fed engines have a small primer bulb on the carburettor that you press 2 or 3 times to help cold starting.

*Mower engine primer*

# Fuel - Maintenance

## Fuel Filters

There should be at least one filter in the fuel line to catch dirt before it gets into the engine. Filters can be inside the fuel tank, in the fuel line and at the point where the fuel goes into the carburettor/injection system.

Fuel filters need to be maintained at regular intervals. Some filters you can clean and reuse many times. Some you remove from the fuel line and replace with a new one.

There are many types of filter:

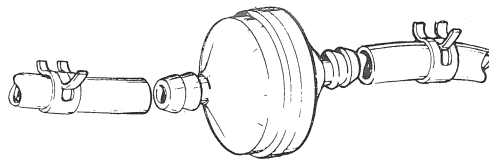

### Sealed element filters

These filters are usually fitted in the fuel line. They have a filter element inside a sealed cartridge. The cartridge is usually made of a clear plastic so that you can see inside.

These filters cannot be cleaned.

Replace the whole filter when it looks dirty, or every 12 months.

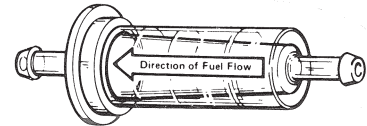

- Undo the clips holding the fuel lines to the filter and pull-off the rubber tubes.
- Remove any screws or clips holding the filter cartridge in place.
- Remove the cartridge and replace with a new one. The cartridge will be marked with an arrow to show the direction of fuel flow through the filter. Re-connect the fuel lines with the arrow pointing *towards* the engine.
- Check for leaks.

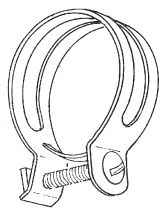

Screw clamps

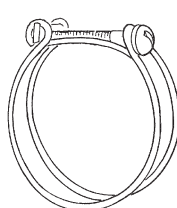

Worm drive

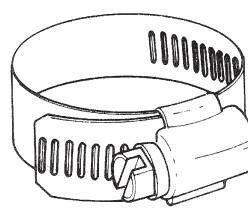

Snap ring

## Mesh filters

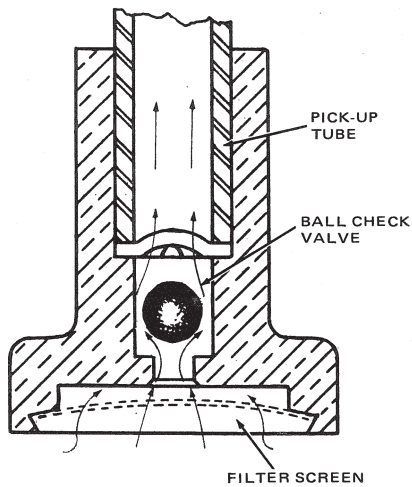

**Inside the fuel tank**, attached to the fuel pickup tube is a wire mesh sock or screen. This prevents large pieces of rust or dirt from being sucked into the fuel system. It can get clogged with dirt or other debris.

Empty fuel from the tank and remove the pickup tube from the tank to wipe or blow the dirt from the mesh.

At the carburettor or fuel pump. There is often another wire mesh filter at the point where fuel enters the engine. It will be a very fine mesh made of wire or plastic.

Remove the filter and wash in clean fuel or blow through it to remove dirt. Take care – the mesh is easily damaged.

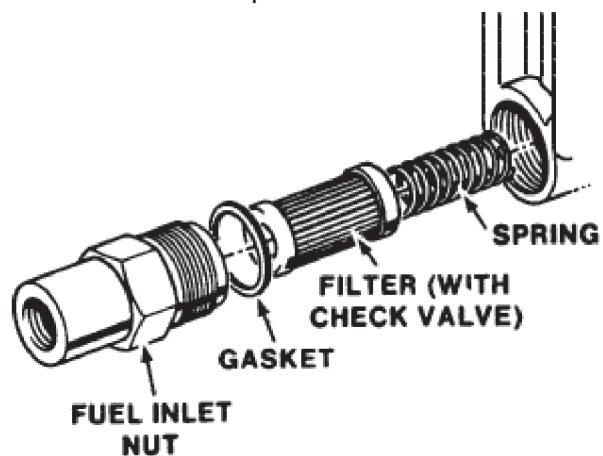

## Check

Check the filter every 100 running hours. Replace or clean depending on the type.

# Fuel Tanks

## Check

Check for damage or fuel leaks from the tank and fittings.

Check/clean fuel filters – for damage, dirt or water

Check the valve in the fuel cap.

# Fuel lines and pumps

## Check

Check all fuel lines and primer pumps and connections for any splits, damage or fuel or air leaks.

Replace or repair straight way.

## Note for outboard motor users

If a fuel pump or line fails while you are at sea, it could be possible to re-fix the tank and lines so that the fuel will gravity feed to the engine. This could be possible in an emergency – but it could be dangerous!

Talk to your tutor about what you could do on your engine/boat in an emergency.

## Activity - fuel

### Safety note

- Petrol is extremely explosive.
  - so don't smoke or use electric equipment when working on fuel systems !
  - don't work on fuel systems in a closed-in area
  - wipe up any fuel spills straight away
- Don't breath-in petrol fumes – they can damage your lungs.
- Avoid getting petrol on your hands and skin. It can dry-out your skin and can cause rashes and other skin problems.





### Find out and write down

For YOUR engine:

What fuel does it use?      Petrol   or   Petroil mix

What grade of petrol?      \_\_\_\_\_

What type of 2-stroke oil?      \_\_\_\_\_

What oil/petrol mix ratio?      \_\_\_\_\_

What type of fuel filters does it have?      \_\_\_\_\_

Where is it?      \_\_\_\_\_

If you have a replace-only filter, what is it's part number?      \_\_\_\_\_

What type of fuel tank do you have?      \_\_\_\_\_

How much does it hold?      \_\_\_\_\_

What type of fuel line?      \_\_\_\_\_

Primer?      \_\_\_\_\_

What checks on the fuel system must you make:

every time you use the engine?      \_\_\_\_\_

every month?      \_\_\_\_\_

### Things to do

Carry out the checks above

Check each fuel filter and clean or replace it.

