



basic education

Department:
Basic Education
REPUBLIC OF SOUTH AFRICA

NATIONAL SENIOR CERTIFICATE

GRADE 12

ELECTRICAL TECHNOLOGY

FEBRUARY/MARCH 2014

MARKS: 200

TIME: 3 hours

This question paper consists of 12 pages and 1 formula sheet.



INSTRUCTIONS AND INFORMATION

1. Answer ALL the questions.
2. Sketches and diagrams must be large, neat and fully labelled.
3. ALL calculations must be shown and must be correctly rounded off to TWO decimal places.
4. Number the answers correctly according to the numbering system used in this question paper.
5. Non-programmable calculators may be used.
6. Show the units of answers for all calculations.
7. A formula sheet is attached at the end of this question paper.
8. Write neatly and legibly.



QUESTION 1: TECHNOLOGY, SOCIETY AND THE ENVIRONMENT

- 1.1 Technological advancements have an impact on society.
- 1.1.1 State ONE modern invention in electrical technology. (1)
- 1.1.2 Describe ONE advantage of the invention in QUESTION 1.1.1 for society. (2)
- 1.2 The generation of electricity is crucial to the economy of South Africa.
- 1.2.1 Name TWO positive effects of the generation of electricity on society. (2)
- 1.2.2 Describe ONE negative effect the generation of electricity will have on the environment. (2)
- 1.3 Name ONE skill an entrepreneur needs to be successful. (1)
- 1.4 Unemployment is a huge problem in any country. Explain how entrepreneurs may help to reduce this problem. (2)
- [10]**

QUESTION 2: TECHNOLOGICAL PROCESS

- 2.1 A power source is needed to test the PAT project. Name THREE power sources which may be used to supply power to the PAT project. (3)
- 2.2 With regard to the technological process, describe the term *design specifications*. (2)
- 2.3 Give ONE example of a design specification. (2)
- 2.4 Explain why investigation forms an important part of the PAT design. (3)
- [10]**

QUESTION 3: OCCUPATIONAL HEALTH AND SAFETY

- 3.1 List FOUR unsafe conditions in an electrical workshop. (4)
- 3.2 Explain why safety signs are important in an electrical workshop. (3)
- 3.3 Describe the negative effect HIV/Aids may have on the workforce. (3)
- [10]**



QUESTION 4: THREE-PHASE AC GENERATION

- 4.1 State TWO advantages of three-phase generation over single-phase generation. (2)
- 4.2 Name TWO methods used to improve the power factor of a resistive inductive load. (2)
- 4.3 A three-phase delta-connected motor draws 25 A from a 380 V/50 Hz supply at a power factor of 0,9 lagging.

Given:

$$\begin{aligned}I_L &= 25 \text{ A} \\ \cos \theta &= 0,9 \\ V_L &= 380 \text{ V} \\ f &= 50 \text{ Hz}\end{aligned}$$

Calculate:

- 4.3.1 The input power (3)
- 4.3.2 The apparent power (3)
- [10]**

QUESTION 5: RLC CIRCUITS

- 5.1 State TWO practical applications of RLC circuits. (2)
- 5.2 An incandescent lamp is connected in series with a capacitor across an AC power supply.
- 5.2.1 State what will happen to the brightness of the lamp when the capacitance of the capacitor is decreased. (1)
- 5.2.2 Explain what will happen to the brightness of the lamp if the frequency of the supply is increased. (4)
- 5.3 Explain the term *capacitive reactance* with reference to an AC circuit. (2)
- 5.4 A 47 Ω resistor, a 0,22 H inductor and a 55 μF capacitor are all connected in parallel across a 220 V/50 Hz supply.

Given:

$$\begin{aligned}R &= 47 \Omega \\ L &= 0,22 \text{ H} \\ C &= 55 \mu\text{F} \\ V &= 220 \text{ V} \\ f &= 50 \text{ Hz}\end{aligned}$$



Calculate:

5.4.1 The inductive reactance of the circuit (3)

5.4.2 The capacitive reactance of the circuit (3)

5.4.3 The current flowing through each component (9)

5.4.4 The supply current (3)

5.5 FIGURE 5.1 shows a series RLC circuit. Calculate the supply voltage of the circuit.

Given:

$$\begin{aligned}V_R &= 100 \text{ V} \\V_L &= 261 \text{ V} \\V_C &= 65 \text{ V} \\f &= 50 \text{ Hz}\end{aligned}$$

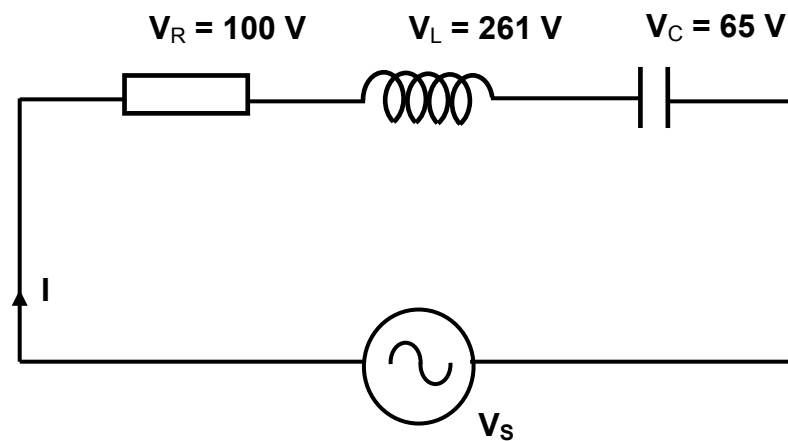

FIGURE 5.1: RLC CIRCUIT

(3)
[30]



QUESTION 6: SWITCHING AND CONTROL CIRCUITS

- 6.1 Draw a fully labelled symbol of a TRIAC. (3)
- 6.2 Describe TWO methods to switch on a TRIAC. (4)
- 6.3 Explain ONE advantage of a TRIAC over an SCR. (2)
- 6.4 The diagram in FIGURE 6.1 shows the characteristic curve of a DIAC.

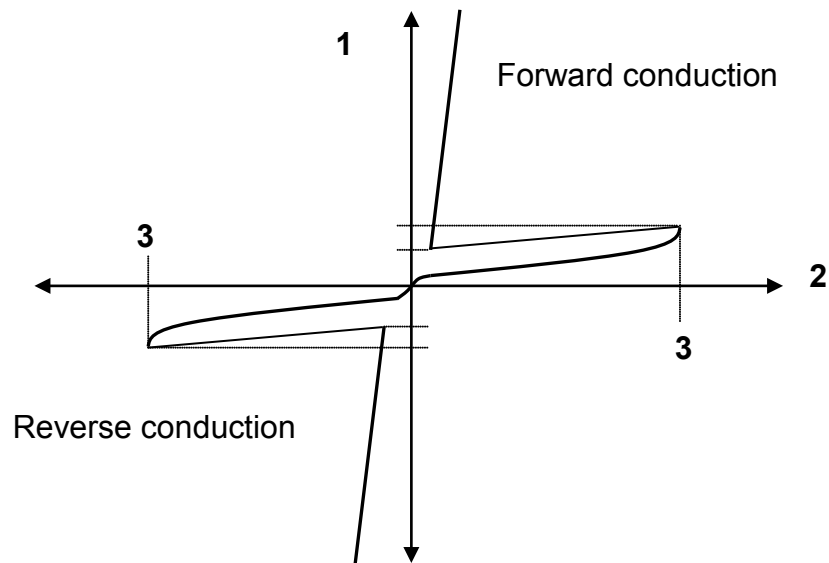
**FIGURE 6.1: CHARACTERISTIC CURVE OF A DIAC**

- 6.4.1 Name the units of axis 1 and axis 2. (2)
- 6.4.2 State what happens to the voltage and current of the DIAC at point 3. (2)
- 6.4.3 Describe ONE method to switch off a DIAC. (2)



6.5 The circuit diagram in FIGURE 6.2 is connected across a 220 V/50 Hz supply. The circuit uses an SCR to control the brightness of the lamp.

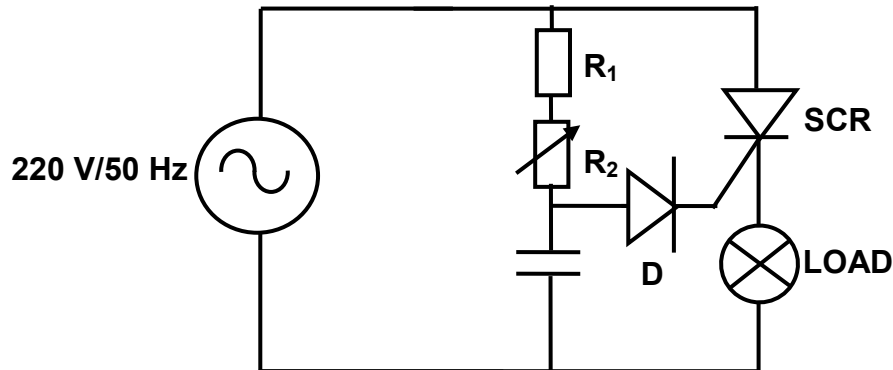

FIGURE 6.2: LAMP-DIMMING CIRCUIT

- 6.5.1 State the function of R_1 . (1)
 - 6.5.2 Describe how the brightness of the lamp is controlled by the circuit. (5)
 - 6.5.3 Draw the output voltage waveform across the lamp if the firing angle of the SCR is 45° . (4)
- [25]**



QUESTION 7: AMPLIFIERS

7.1 List THREE characteristics of an ideal op amp. (3)

7.2 FIGURE 7.1 shows an op-amp circuit.

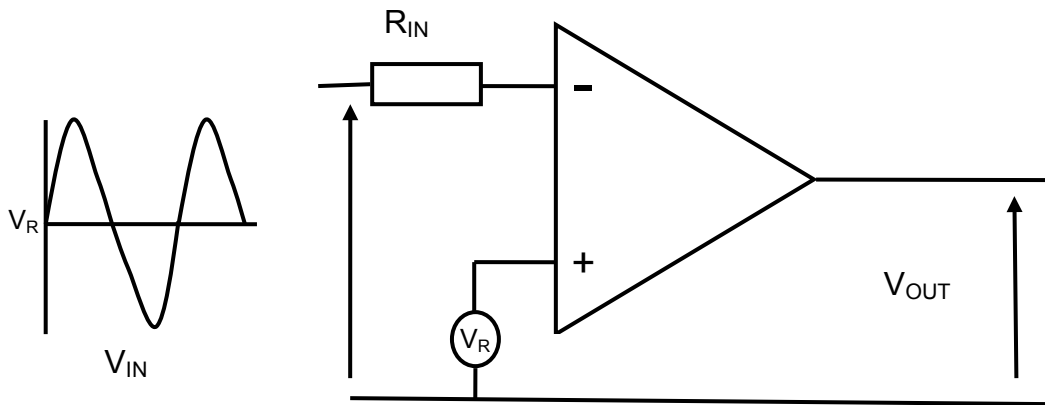

FIGURE 7.1: OP-AMP CIRCUIT

7.2.1 Name the op-amp circuit. (1)

7.2.2 Draw the input and output waveforms. (3)

7.3 FIGURE 7.2 is a block diagram of a feedback circuit.

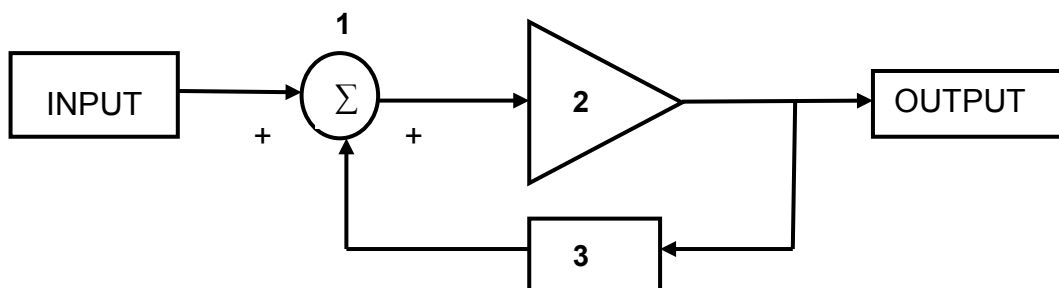

FIGURE 7.2: BLOCK DIAGRAM OF A FEEDBACK CIRCUIT

7.3.1 Identify the type of feedback in this circuit. (1)

7.3.2 Name labels 1, 2 and 3. (3)

7.4 Explain the purpose of negative feedback in linear amplifiers. (2)

7.5 Name the TWO basic modes in which op amps may be connected. (2)

7.6 State TWO applications of an op amp. (2)

7.7 State TWO disadvantages of op amps. (2)

7.8 Draw a circuit of an inverting op amp. (6)

[25]



QUESTION 8: THREE-PHASE TRANSFORMERS

8.1 The diagram in FIGURE 8.1 shows a three-phase step-down transformer.

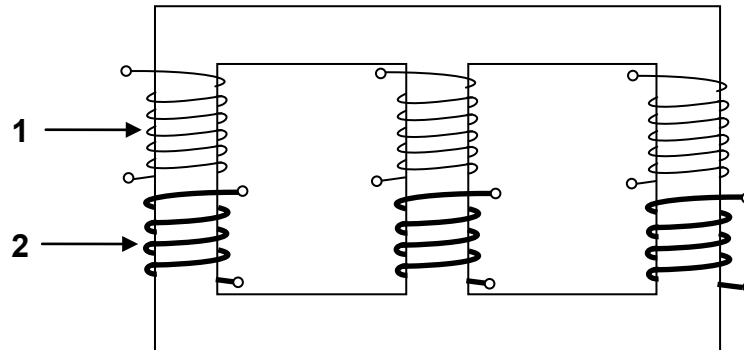

FIGURE 8.1: THREE-PHASE STEP-DOWN TRANSFORMER

- 8.1.1 Name winding 1 and winding 2. (2)
- 8.1.2 State ONE combination in which the transformer can be connected. (1)
- 8.1.3 Describe why one set of coils has a thicker gauge than the other set of coils. (3)

8.2 A three-phase transformer is connected in delta-star and delivers 12 kW at full load. The transformer has a power factor of 0,8 and an efficiency of 100%.

Given:

$$P_{\text{OUT}} = 12 \text{ kW}$$

$$\eta = 100\%$$

$$\text{Cos } \theta = 0,8$$

- 8.2.1 Calculate the input kVA to the transformer (apparent power). (3)
- 8.2.2 State and describe ONE transformer loss. (3)
- 8.2.3 If the load of the transformer is decreased, describe how this will affect the primary and secondary current of the transformer. (3)

[15]



QUESTION 9: LOGIC CONCEPTS AND PLCs

- 9.1 Draw a block diagram of a basic PLC system. (4)
- 9.2 Name TWO applications of a PLC. (2)
- 9.3 Describe the term *ladder logic* used in the programming of PLCs. (3)
- 9.4 Name TWO types of counters used in logic systems. (2)
- 9.5 List THREE basic operands used in the programming of PLCs. (3)
- 9.6 Draw the ladder diagram symbols of the following:
- 9.6.1 Relay or other type of device used as an output from a PLC (1)
- 9.6.2 A normally closed switch or other type of normally closed device used as an input to a PLC (1)
- 9.6.3 A normally open switch or other type of normally open device used as input to a PLC (1)
- 9.7 FIGURE 9.1 shows a ladder diagram.

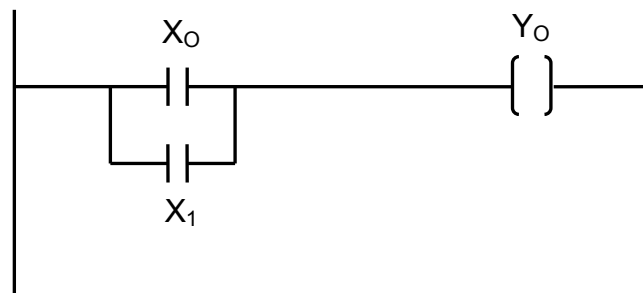
**FIGURE 9.1: LADDER DIAGRAM**

- 9.7.1 Draw the circuit diagram represented in FIGURE 9.1. (3)
- 9.7.2 Name the logic gate the circuit represents. (1)
- 9.7.3 Draw the truth table for the logic gate in QUESTION 9.7.2. (4)
- 9.7.4 Draw the logic symbol that represents the gate in QUESTION 9.7.2. (2)



9.8 FIGURE 9.2 shows a control circuit.

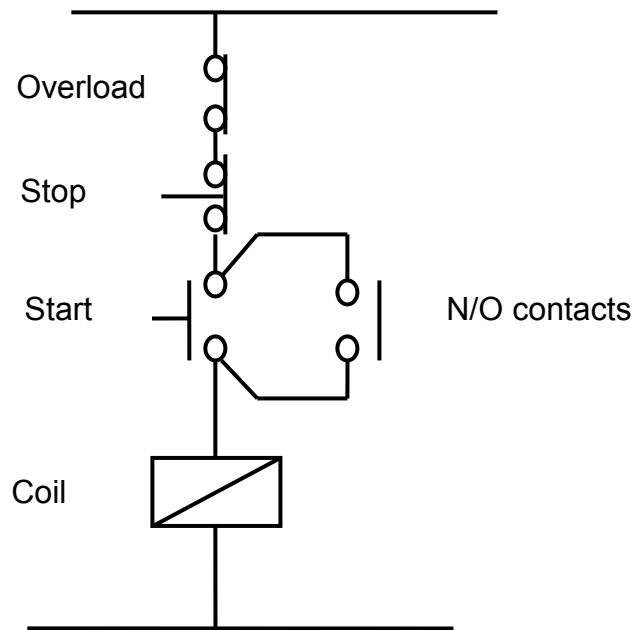

FIGURE 9.2: CONTROL CIRCUIT

- 9.8.1 Name the control circuit. (1)
 - 9.8.2 Draw the ladder logic programming diagram for this circuit. (6)
 - 9.8.3 Name a practical application of the circuit. (1)
- [35]**



QUESTION 10: THREE-PHASE MOTORS AND CONTROL

- 10.1 Name THREE parts of a three-phase induction motor. (3)
- 10.2 State ONE loss that occurs in an induction motor. (1)
- 10.3 Name THREE practical uses of three-phase motors. (3)
- 10.4 Describe the function of an emergency stop button. (2)
- 10.5 State where an emergency stop button must be located. (1)
- 10.6 Explain what will happen if a short circuit occurs in one winding of a three-phase motor. (2)
- 10.7 Describe why it is important to test the insulation resistance between the windings and the frame of the motor. (3)
- 10.8 Describe the function of an overload unit in a motor control circuit. (3)
- 10.9 Describe the function of a star-delta starter. (3)
- 10.10 A 5 kW motor is connected in delta to a 380 V/50 Hz supply. The motor has a power factor of 0,8.
- Given:
- $P = 5 \text{ kW}$
 $V_L = 380 \text{ V}$
 $f = 50 \text{ Hz}$
 $\text{pf} = 0,8$
- Calculate:
- 10.10.1 The line current drawn by the motor at full load (3)
- 10.10.2 The phase current drawn by the motor at full load (3)
- 10.11 If the power factor of the three-phase induction motor was improved, describe what would happen to the apparent power of the motor. (3)

[30]**TOTAL: 200**

FORMULA SHEET

$$X_L = 2\pi FL$$

$$X_C = \frac{1}{2\pi FC}$$

$$Z = \sqrt{R^2 + (X_L \cong X_C)^2}$$

$$I_T = \sqrt{I_R^2 + (I_C \cong I_L)^2}$$

$$V_T = \sqrt{V_R^2 + (V_C \cong V_L)^2}$$

$$V_R = IR$$

$$V_L = IX_L$$

$$V_C = IX_C$$

$$f_r = \frac{1}{2\pi\sqrt{LC}}$$

$$Q = \frac{1}{R}\sqrt{\frac{L}{C}}$$

$$Q = \frac{X_L}{R} = \frac{V_L}{V_R}$$

$$\cos\theta = \frac{I_R}{I_T}$$

$$\cos\theta = \frac{R}{Z}$$

$$\left. \begin{aligned} P &= VI \cos\theta \\ S &= VI \\ Q &= VI \sin\theta \end{aligned} \right\} \text{Single phase}$$

$$\left. \begin{aligned} P &= \sqrt{3} V_L I_L \cos\theta \\ S &= \sqrt{3} V_L I_L \\ Q &= \sqrt{3} V_L I_L \sin\theta \end{aligned} \right\} \text{Three phase}$$

$$\left. \begin{aligned} V_L &= V_{Ph} \\ I_L &= \sqrt{3} I_{Ph} \end{aligned} \right\} \text{Delta}$$

$$\left. \begin{aligned} V_L &= \sqrt{3} V_{Ph} \\ I_L &= I_{Ph} \end{aligned} \right\} \text{Star}$$

$$f = \frac{1}{T}$$

$$\frac{V_{ph(P)}}{V_{ph(S)}} = \frac{N_P}{N_S} = \frac{I_{ph(S)}}{I_{ph(P)}}$$



FORMULEBLAD

$$\begin{aligned}
 X_L &= 2\pi f L \\
 X_C &= \frac{1}{2\pi f C} \\
 Z &= \sqrt{R^2 + (X_L - X_C)^2} \\
 I_T &= \sqrt{I_C^2 + (I_L)^2} \\
 V_T &= \sqrt{V_C^2 + (V_L)^2} \\
 V_R &= I R \\
 V_L &= I X_L \\
 V_C &= I X_C \\
 f &= \frac{1}{2\pi \sqrt{LC}} \\
 \tilde{O} &= \frac{1}{\sqrt{L}} \sqrt{\frac{C}{L}} \\
 \tilde{O} &= \frac{R}{X_L} = \frac{R}{\omega L} \\
 \cos\theta &= \frac{I_R}{I} \\
 \cos\theta &= \frac{Z}{R} \\
 \left. \begin{aligned} P &= VI \cos\theta \\ S &= VI \\ \tilde{O} &= VI \sin\theta \end{aligned} \right\} \text{Enkeifase}
 \end{aligned}$$

$$\begin{aligned}
 P &= \sqrt{3} V_L I_L \cos\theta \\
 S &= \sqrt{3} V_L I_L \\
 \tilde{O} &= \sqrt{3} V_L I_L \sin\theta \\
 \left. \begin{aligned} P &= \sqrt{3} V_L I_L \cos\theta \\ S &= \sqrt{3} V_L I_L \\ \tilde{O} &= \sqrt{3} V_L I_L \sin\theta \end{aligned} \right\} \text{Driefase} \\
 V_L &= V_{ph} \\
 I_T &= \sqrt{3} I_{ph} \\
 \left. \begin{aligned} V_L &= V_{ph} \\ I_T &= \sqrt{3} I_{ph} \end{aligned} \right\} \text{Delta} \\
 V_L &= \sqrt{3} V_{ph} \\
 I_T &= I_{ph} \\
 \left. \begin{aligned} V_L &= \sqrt{3} V_{ph} \\ I_T &= I_{ph} \end{aligned} \right\} \text{Ster} \\
 f &= \frac{1}{T} \\
 \frac{V^{(s)hd}}{I^{(s)hd}} &= \frac{V^{(s)} N^d}{I^{(s)} N^d} = \frac{V^s N^s}{I^s N^s} = \frac{V^{(d)hd}}{I^{(d)hd}}
 \end{aligned}$$





VRAAG 10: DRIEFASEMOTORS EN BEHEER

10.1 Noem DRIE onderdele van 'n driefase-induksiemotor. (3)

10.2 Noem EEN verlies wat in 'n induksiemotor voorkom. (1)

10.3 Noem DRIE praktiese gebruike van driefasemotors. (3)

10.4 Beskryf die funksie van 'n noodstopkakelaar. (2)

10.5 Noem waar 'n noodstopkakelaar geplaas moet wees. (1)

10.6 Verduidelik wat sal gebeur as daar 'n kortsluiting in een van die wikkelings van 'n driefasemotor plaasvind. (2)

10.7 Beskryf waarom dit belangrik is om die isolasieweerstand tussen die wikkelings en die raam van die motor te toets. (3)

10.8 Beskryf die funksie van 'n oorbelastingseenheid in 'n motorbeheerkring. (3)

10.9 Beskryf die funksie van 'n ster-delta-aansitter. (3)

10.10 'n 5 kW-motor is in delta aan 'n 380 V/50 Hz-toevoer verbind. Die motor het 'n arbeidsfaktor van 0,8.

Gegee:

$$\begin{aligned}
 P &= 5 \text{ kW} \\
 V_L &= 380 \text{ V} \\
 f &= 50 \text{ Hz} \\
 \text{pf} &= 0,8
 \end{aligned}$$

Bereken:

10.10.1 Die lynstroom wat teen volvas deur die motor getrek word (3)

10.10.2 Die fasestroom wat teen volvas deur die motor getrek word (3)

10.11 As die arbeidsfaktor van die driefase-induksiemotor verbeter sou word, beskryf wat met die skyndrywing van die motor sou gebeur. (3)

TOTAAL: 200

[30]



[35]

(1)

9.8.3 Noem 'n praktiese toepassing van die kring.

(6)

9.8.2 Teken die leerlogikaprogrammeringsdiagram vir hierdie kring.

(1)

9.8.1 Benoem die beheerkring.

FIGUR 9.2: BEHEERKRING

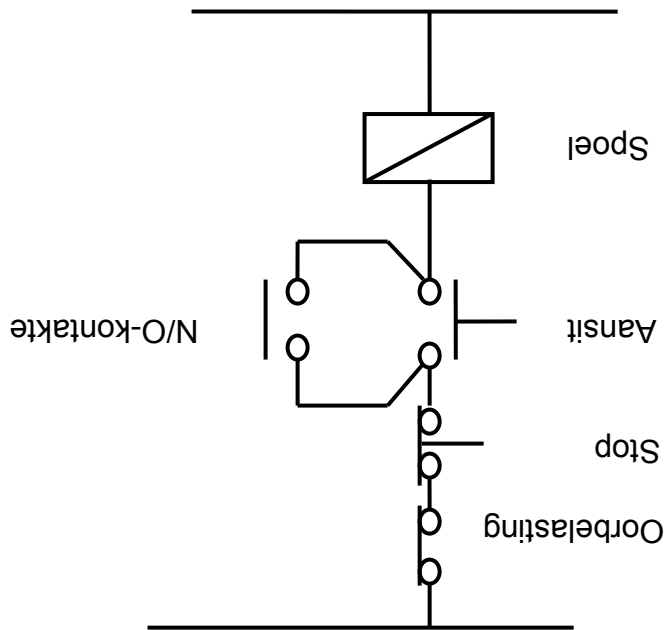

9.8 FIGUR 9.2 toon 'n beheerkring.

VRAAG 9: LOGIKAKONSEPTE EN PLB'S

9.1 Teken 'n blokdiagram van 'n basiese PLB-stelsel. (4)

9.2 Noem TWEE toepassings van 'n PLB. (2)

9.3 Beskryf die term *leerlogika* wat in die programmering van PLB's gebruik word. (3)

9.4 Noem TWEE tipes tellers wat in logikastelsels gebruik word. (2)

9.5 Noem DRIE basiese operande wat in die programmering van PLB's gebruik word. (3)

9.6 Teken die leerdiagramsimbole van die volgende:

9.6.1 Relè of ander tipe toestel wat as 'n uitset van 'n PLB gebruik word (1)

9.6.2 'n Normaal-toe-skakelaar of ander tipe normaal-toe-toestel wat as 'n inset vir 'n PLB gebruik word (1)

9.6.3 'n Normaal-oop-skakelaar of ander tipe normaal-oop-toestel wat as inset vir 'n PLB gebruik word (1)

9.7

FIGUR 9.1 toon 'n leerdiagram.

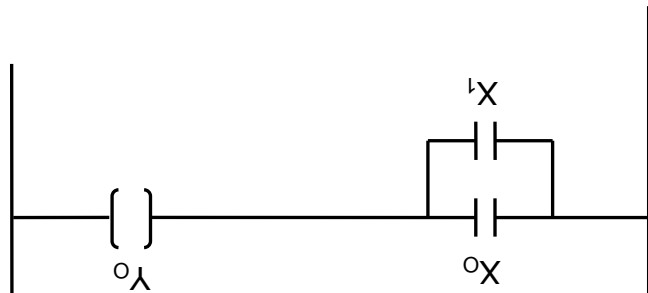

FIGUR 9.1: LEERDIAGRAM

9.7.1 Teken die kringdiagram wat in FIGUR 9.1 voorgestel word. (3)

9.7.2 Noem die logikahek wat deur die kring voorgestel word. (1)

9.7.3 Teken die waarheidstabel vir die logikahek in VRAAG 9.7.2. (4)

9.7.4 Teken die logikasimbool wat die hek in VRAAG 9.7.2 voorstel. (2)





8.2

'n Driefasetransformator is in delta-ster verbind en lewer 12 kW teen vollas. Die transformator het 'n arbeidsfaktor van 0,8 en 'n rendement van 100%.

Gegee:

$$P_{uit} = 12 \text{ kW}$$

$$\eta = 100\%$$

$$\cos \theta = 0,8$$

- 8.2.1 Bereken die inset-kVA na die transformator (skyndrywing). (3)
 - 8.2.2 Noem en beskryf EEN transformatorverlies. (3)
 - 8.2.3 As die las van die transformator vermindert word, beskryf hoe dit die primêre en sekondêre stroom van die transformator sal beïnvloed. (3)
- [15]

FIGUR 8.1: DRIEFASEVERLAGINGSTRANSFORMATOR

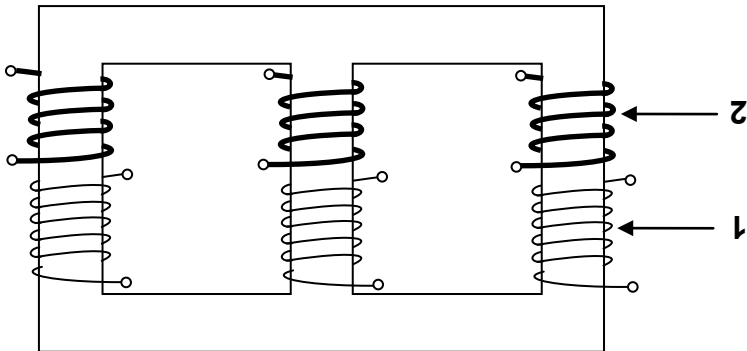

8.1 Die diagram in FIGUR 8.1 toon 'n driefaseverlagingstransformator.

VRAAG 8: DRIEFASETRANSFORMATORS

VRAAG 7: VERSTERKERS

- 7.1 Noem DRIE kenmerke van 'n ideale operasionele versterker. (3)
- 7.2 FIGUR 7.1 toon 'n operasionele versterker-kring. (3)

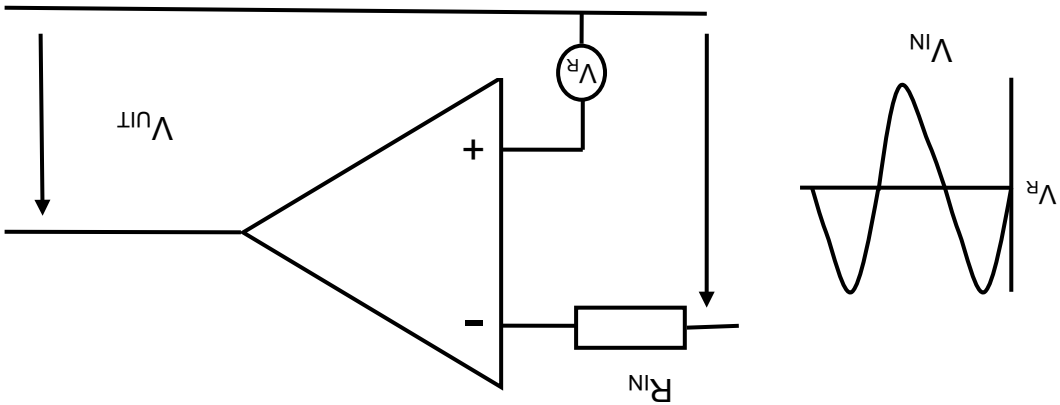

FIGUR 7.1: OPERASIONELE VERSTERKER-KRING

- 7.2.1 Benoem die operasionele versterker-kring. (1)
- 7.2.2 Teken die inset- en uitsetgolfvorms. (3)

7.3 FIGUR 7.2 is 'n blokdiagram van 'n terugvoerkring.

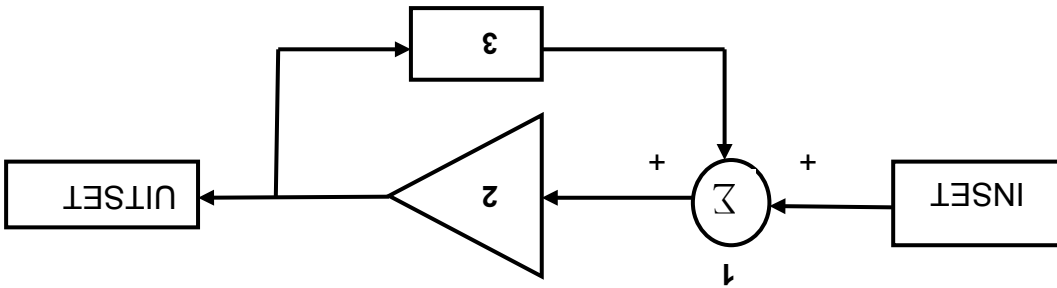

FIGUR 7.2: BLOKDIAGRAM VAN 'N TERUGVOERKRING

- 7.3.1 Identifiseer die tipe terugvoer in hierdie kring. (1)
- 7.3.2 Benoem byskrif 1, 2 en 3. (3)

- 7.4 Verduidelik die doel van negatiewe terugvoer in lineêre versterkers. (2)
- 7.5 Noem die TWEE basiese modusse waarin operasionele versterkers verbind kan word. (2)
- 7.6 Noem TWEE toepassings van 'n operasionele versterker. (2)
- 7.7 Noem TWEE nadele van operasionele versterkers. (2)
- 7.8 Teken 'n kring van 'n omkeer- operasionele versterker. (6)

[25]



6.5

Die kringdiagram in FIGUR 6.2 is aan 'n 220 V/50 Hz-toevoer verbind. Die kring gebruik 'n SBG om die helderheid van die lamp te beheer.

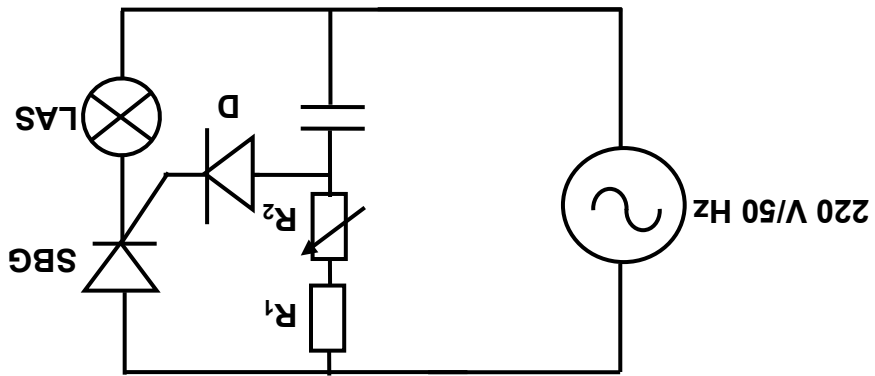

FIGUR 6.2: LIGDEMPKRING

- 6.5.1 Noem die funksie van R_1 . (1)
- 6.5.2 Beskryf hoe die helderheid van die lamp deur die kring beheer word. (5)
- 6.5.3 Teken die uitsetspanning se golfvorm oor die lamp as die SBG se vuurhoek 45° is. (4)

[25]



VRAAG 6: SKAKEL- EN BEHEERKRINGE

- 6.1 Teken 'n volledig benoemde simbool van 'n TRIAK. (3)
- 6.2 Beskryf TWEE metodes om 'n TRIAK aan te skakel. (4)
- 6.3 Verduidelik EEN voordeel van 'n TRIAK bo 'n SBG. (2)
- 6.4 Die diagram in FIGUR 6.1 toon die kenkromme van 'n DIAK. (2)

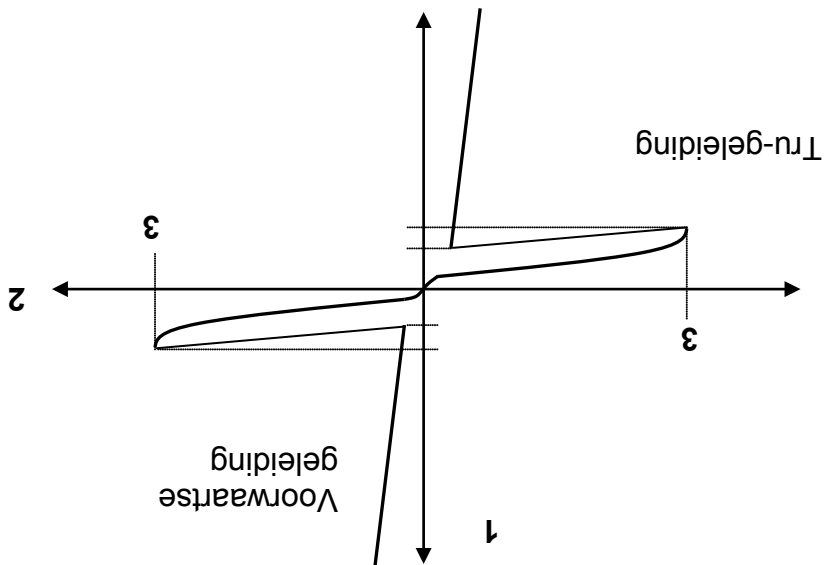

FIGUR 6.1: KENKROMME VAN 'N DIAK

- 6.4.1 Noem die eenheid van as 1 en as 2. (2)
- 6.4.2 Noem wat met die spanning en stroom van die DIAK by punt 3 gebeur. (2)
- 6.4.3 Beskryf EEN metode om 'n DIAK af te skakel. (2)



Bereken:

5.4.1 Die induktiewe reaktansie van die kring (3)

5.4.2 Die kapasitiewe reaktansie van die kring (3)

5.4.3 Die stroom wat deur elke komponent vloei (9)

5.4.4 Die toeverstroom (3)

5.5 FIGUR 5.1 toon 'n serie-RLC-kring. Bereken die toevorspanning van die kring.

Gegee:

- $V_R = 100 \text{ V}$
- $V_L = 261 \text{ V}$
- $V_C = 65 \text{ V}$
- $f = 50 \text{ Hz}$

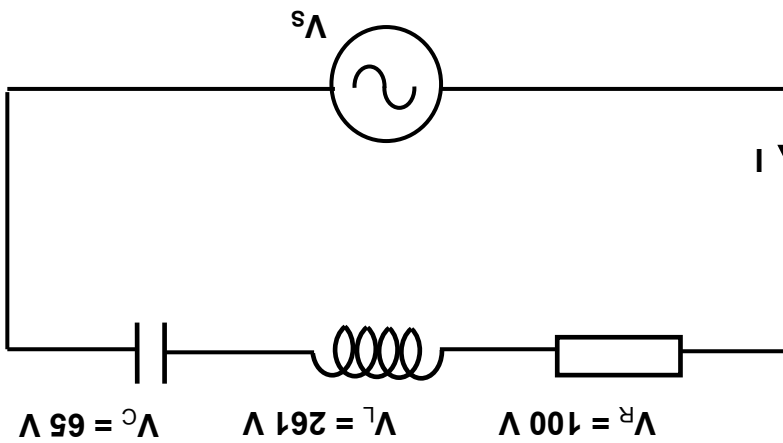

FIGUR 5.1: RLC-KRING

(3)
[30]



VRAAG 4: DRIEFASE-WS-OPWEKKING

- 4.1 Noem TWEE voordele van driefase-opwekking bo enkelefas-opwekking. (2)
- 4.2 Noem TWEE metodes wat gebruik word om die arbeidsfaktor van 'n weerstands-induktiewe las te verbeter. (2)
- 4.3 'n Driefase-deltaverbinde motor trek 25 A vanaf 'n 380 V/50 Hz-toevoer teen 'n arbeidsfaktor van 0,9 nalopend. (3)

Gegee:

$$I_L = 25 \text{ A}$$

$$\cos \phi = 0,9$$

$$V_L = 380 \text{ V}$$

$$f = 50 \text{ Hz}$$

Bereken:

- 4.3.1 Die insetdrywing (3)
- 4.3.2 Die skyndrywing (3)

[10]

VRAAG 5: RLC-KRINGE

- 5.1 Noem TWEE praktiese toepassings van RLC-kringe. (2)
- 5.2 'n Gloeilamp word in serie aan 'n kapasitor aan 'n WS-toevoer verbind. (1)
- 5.2.1 Noem wat met die helderheid van die lamp sal gebeur wanneer die kapasitansie van die kapasitor verminder word. (1)
- 5.2.2 Verduidelik wat met die helderheid van die lamp sal gebeur as die frekwensie van die toevoer verhoog word. (4)
- 5.3 Verduidelik die term *kapasitiewe reaktansie* met verwysing na 'n WS-kring. (2)
- 5.4 'n 47 Ω-resistor, 'n 0,22 H-induktor en 'n 55 μF-kapasitor word almal in parallel aan 'n 220 V/50 Hz-toevoer verbind. (2)

Gegee:

$$R = 47 \Omega$$

$$L = 0,22 \text{ H}$$

$$C = 55 \mu\text{F}$$

$$V = 220 \text{ V}$$

$$f = 50 \text{ Hz}$$





- 3.3 Beskryf die negatiewe invloed wat MIV/Vigs op die arbeidsmag kan hê. [10]
(3)
- 3.2 Verduidelik hoekom veiligheidsstekens in 'n elektriese werkwinkel belangrik is. (3)
- 3.1 Noem VIER onveilige toestande in 'n elektriese werkwinkel. (4)

VRAAG 3: BEROEPSGESONDHEID EN -VEILIGHEID

- 2.4 Verduidelik hoekom ondersoek 'n belangrike deel van die PAT-ontwerp uitmaak. (3)
- 2.3 Gee EEN voorbeeld van 'n ontwerpspesifikasie. (2)
- 2.2 Met betrekking tot die tegnologiese proses, beskryf die term *ontwerpspesifikasies*. (2)
- 2.1 'n Kragbron is nodig om die PAT-projek te toets. Noem DRIE kragbronne wat gebruik kan word om krag aan die PAT-projek te voorsien. (3)

VRAAG 2: TEGNOLOGIESE PROSES

- 1.4 Verloosheid is 'n groot probleem in enige land. Verduidelik hoe entrepreneurs kan help om hierdie probleem te verminder. (2)
- 1.3 Noem EEN vaardigheid wat 'n entrepreneur nodig het om suksesvol te wees. (1)
- 1.2.2 Beskryf EEN negatiewe invloed van die opwekking van elektrisiteit op die omgewing. (2)
- 1.2.1 Noem TWEE positiewe invloede van die opwekking van elektrisiteit op die gemeenskap. (2)
- 1.2 Die opwekking van elektrisiteit is noodsaaklik vir die ekonomie van Suid-Afrika. (2)
- 1.1.2 Beskryf EEN voordeel van die uitvinding in VRAAG 1.1.1 vir die gemeenskap. (2)
- 1.1.1 Noem EEN moderne uitvinding in elektriese tegnologie. (1)
- 1.1 Tegnologiese vooruitgang het 'n impak op die gemeenskap. (1)

VRAAG 1: TEGNOLOGIE, GEMEENSAP EN DIE OMGEWING



1. Beantwoord AL die vrae.
2. Sketse en diagramme moet groot en netjies met volledige byskrifte wees.
3. ALLE berekeninge moet getoon word en korrek tot TWEE desimale plekke afgerond word.
4. Nommer die antwoorde korrek volgens die nommeringstelsel wat in hierdie vraestel gebruik is.
5. Nieprogrammeerbare sakrekenaars mag gebruik word.
6. Toon die eenhede vir antwoorde van alle berekeninge.
7. 'n Formuleblad is aan die einde van hierdie vraestel aangeheg.
8. Skryf netjies en leesbaar.

INSTRUKSIES EN INLIGTING



Hierdie vraestel bestaan uit 12 bladsye en 1 formuleblad.

TYD: 3 uur

PUNTE: 200

ELEKTRIESE TEGNOLOGIE
FEBRUARIE/MART 2014

GRAAD 12

**NASIONALE
SENIOR SERTIFIKAT**

Department:
Basic Education
REPUBLIC OF SOUTH AFRICA

basic education

