



basic education

Department:
Basic Education
REPUBLIC OF SOUTH AFRICA

NATIONAL SENIOR CERTIFICATE

GRADE 12

AGRICULTURAL TECHNOLOGY

NOVEMBER 2011

MEMORANDUM

MARKS: 200

This memorandum consists of 11 pages.

SECTION A**QUESTION 1**

1.1	X	B	C
1.2	A	B	X
1.3	X	B	C
1.4	A	X	C
1.5	A	B	X
1.6	A	B	X
1.7	A	B	X
1.8	A	B	X
1.9	A	B	X
1.10	X	B	C
1.11	A	B	X
1.12	X	B	C
1.13	A	B	X
1.14	A	B	X
1.15	A	X	C
1.16	X	B	C
1.17	X	B	C
1.18	X	B	C
1.19	X	B	C
1.20	X	X	X

TOTAL SECTION A: 40

SECTION B**QUESTION 2: MATERIALS AND STRUCTURES**

- 2.1 2.1.1
- Copper✓
 - Lead✓
 - Tin✓
 - Aluminium
 - Zinc
 - Brass
- (3)
(Any 3)

2.1.2	ALLOY	METALS	
	(a) Stainless steel	Manganese, ✓ Chromium, ✓ Nickel✓	(3)
	(b) Brass	Copper, ✓ Tin✓	(2)
	(c) Solder	Lead✓, Tin✓	(2)

- 2.2 2.2.1 Type of material to be joined. ✓
Conditions under which this joint will be used. ✓
(Can provide an example) (2)

- 2.2.2 High temperatures ✓
Chemical reactions ✓
Corrosion
Stress cracking (Any 2) (2)

- 2.2.3
- Catalyst and accelerator should always be stored separately. ✓
(Explosion)
 - Remove all resin catalyst and accelerator from skin. ✓
 - Wear gloves if skin is sensitive. ✓
 - Only use acetone in well-ventilated room.
 - Handle resin casting carefully because they are brittle.
 - Do not breathe in glass fibre (3)
 - Do not get it in your eyes. (Any 3)

- 2.3 2.3.1 600 x 230 mm ✓✓ (2)

- 2.3.2 Lintels act as support
over window✓ and door openings ✓ (2)

- 2.3.3
- Tiles/Slash stone ✓
 - Corrugated galvanised iron sheets, IBR ✓
 - Grass / Thatch / Reeds ✓
 - Asbestos
 - Concrete slabs
 - Fibre glass
 - Glass (Any 3) (3)

- 2.4 2.4.1 Beam ✓ (1)
- 2.4.2
- Measure the length 1,5 m with a tape ✓
 - Mark it off with pencil ✓
 - Saw the wood at marked length with saw ✓
 - File/sand rough edging ✓ (Any 2 tools and any 2 descriptions) (4)
- 2.4.3 Pink aerolite ✓ or any effective insulating material. (1)
- 2.5 2.5.1 Install lightning conductors/arrestor/earthed ✓
Switch off all electricity during thunderstorms. ✓ (2)
- 2.5.2 Potential for the entire fence to be disabled due to a break in any
conducting wire ✓
Shorting out if the conducting wire makes contact with any non-electrified
components of the fence. ✓
Power failures ✓
Veld fires due to dry vegetation touching the wires.
Children or pets touching wires by accident
(Any correct acceptable answer will be accepted) (Any 3) (3)
- [35]**

QUESTION 3: ENERGY

- 3.1 3.1.1
- Wind turbine with a propeller blade type design. ✓
 - The propeller captures wind energy, used to drive a turbine. ✓
 - The turbine is attached to a generator, which enables the generator to produce power. ✓
- (3)
- 3.1.2
- Cost effectiveness and efficiency. ✓
 - Wind speed to generate adequate electricity efficiently. ✓
 - Open spaces are more suitable. ✓
 - Do not use in mountainous area. ✓
 - Do not use near forests. ✓
 - Expert advice should be gained before purchasing a wind turbine,
 - It can be connected to your power supply to provide your home with an extra boost in electricity
 - Wind energy technology can be combined with other alternative energy sources of energy.
 - Amount of energy needed
 - (Any 5)
- (5)
- 3.2 3.2.1
- Solar power is limitless. ✓
 - Environmentally friendly energy source/ No pollution. ✓
 - Transition losses are limited.
 - Does not use a lot of space.
 - Low maintenance
 - Installation is relative cheap and simple
- (Any 2) (2)
- 3.2.2
- The sun heats up the water in the solar panels, the heated water always rises to the highest point in a closed system. ✓
- The heated water enters the geyser through a closed copper pipe network that runs through the geyser. ✓
- The hot water inside the copper pipes heats up the cold water inside the geyser ✓
- and then flows downwards back to the solar panel where it is reheated. ✓
- (4)
- 3.3
- Low cost. ✓
 - Biodegradable. ✓
 - Less pollution - environment friendly. ✓
 - Regenerate faster than conventional fuels.
 - Engines do not require any radical changes to switch to the use of biofuels.
- (Any 3) (3)
- 3.4 3.4.1 woody plant fibre or natural gas. ✓ (Any 1) (1)
- 3.4.2 maize, sorghum, potatoes, wheat, sugar-cane, cornstalks, fruit and vegetable waste. ✓ (Any 1) (1)
- 3.4.3 earth gas, landfills, kraal manure, rubbish dumps and swamps. ✓ (Any 1) (1)
- [20]**

**QUESTION 4:
SKILLS AND CONSTRUCTION PROCESSES**

4.1

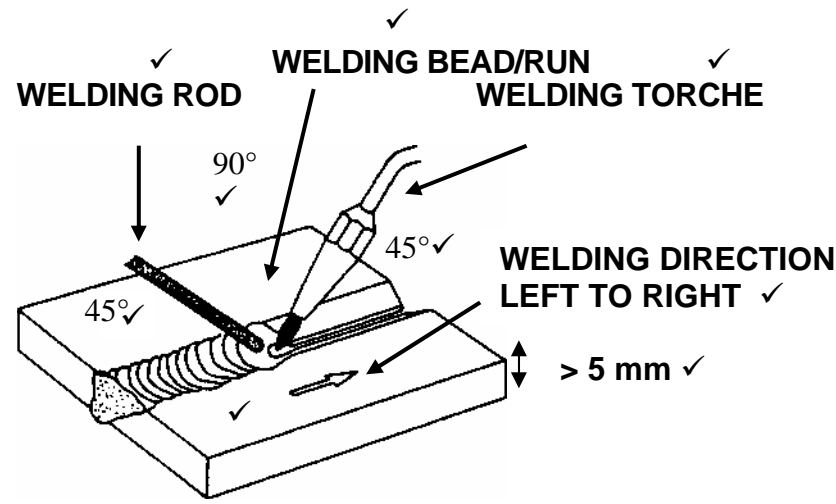

Neatness: 1 Mark ✓

(10)

4.2 4.2.1 Droplets of filler wire/(Arc) ✓
Provides the filling metal for the fusion process/Provides the heat for the welding process. ✓

(2)

4.2.2 Shielding gas. ✓
Prevents the welding bead to come into contact with oxygen during the welding process. ✓

(2)

4.2.3 Argon, ✓
Helium ✓
Carbon dioxide (CO₂). ✓

(3)

4.3 4.3.1

- Welding upwards in a vertical position may pose a problem, because the molten metal of the puddle will tend to run down. ✓
- Special electrode is used for vertical welding with an arc welder, makes the process easier as it 'freezes' more quickly. ✓
- Amperage can be reduced slightly. ✓
- Tip of the electrode must be pointed upwards, so that the electrode forms an angle of up to 30° with the surface. ✓
- Arc must be kept as short as possible and the speed must be just sufficient to prevent the molten metal from the puddle to run down. ✓
- When welding up very little lateral movements of the electrode must be made. ✓

(6)

4.3.2

- Amount of welding. ✓
- Number of welding runs. ✓
- Degree of resistance. ✓

- Original state or condition of parts that must be welded.
 - Welding procedure that follows
 - Thickness of the metal
 - Current strength (Any 3) (3)
- 4.3.3
- Pre-setting of welding piece ✓
 - Short welding runs ✓
 - Clamping ✓
 - Spot welding
 - Bridging
 - Lower welding current (Any 3) (3)
- 4.3.4
- When metal is heated, it expands and when it cools down it shrinks. ✓
The shrinking of welded metal, as well as weld runs, causes distortion of sheets when they cool down. ✓
Shrinking takes place in all directions simultaneously during cooling and therefore causes various types of distortion. ✓ (3)
- 4.4
- It is the process by means of which worn parts ✓
 - can be built up by padding ✓
 - with a wear resistant metal. ✓ (3)

[35]

QUESTION 5: TOOLS, IMPLEMENTS AND EQUIPMENT

- 5.1 5.1.1 The illustration shows how the plough tends to push down on the front wheels✓
when the top link is fitted between the plough and the tractor. ✓ (2)
- 5.1.2
- Ploughing depth. ✓
 - Soil resistance. ✓
 - Forward speed of the tractor. ✓ (3)
- 5.2 5.2.1
- Easily installed or taken off. ✓
 - Used over long distances. ✓
 - Easily lengthened or shortened. ✓
 - Easily joined. ✓
 - Used with ease to run over a pulley situated between two bearings without removing the bearings. ✓ (5)
- 5.2.2
- Safeguard the equipment. ✓
 - Safeguard the operator. ✓
 - Removed and replaced easily. ✓
 - Must appear neat. ✓
 - Must be properly installed. (not loosened while in motion)
 - Weight saving.
 - Keep out all undesired material. (Any 4) (4)
- 5.3
- Any implement can be used on any tractor. ✓
 - The same engine and spares can be used on a variety of tractors. ✓
 - Spares can be purchased from any agent instead of a specific one. ✓
 - Spares can be offered to the farmer relatively cheaply, because of mass production. ✓
 - A reduced quantity of spares needs to be kept in stock for maintenance and service purposes.
 - When a farmer decides to purchase a new tractor, he/she will not have to take a special course to maintain it. (Any 4) (4)
- 5.4 5.4.1
- Do not let people or animals come near the blades or working parts of the machine while it is working. ✓
 - Make sure that all safety devices are in place and in working order. ✓
 - No person other than the driver may ride or climb on top of this machine. ✓ (Any acceptable answer) (3)
- 5.4.2
- All grease points must be well greased. ✓
 - The correct tension must be set for all belts and drives. ✓
 - Check that all parts are functioning correctly. ✓
 - Replace all worn out parts immediately especially the cutter blades. ✓
 - Service according to manufacturer's specifications. ✓
 - Lift up all dust release guards.
 - Check that there is no damage to the blades and that they are sharp. (Any 5) (5)

- 5.5
- Computers help to determine the yield on each specific spot on the land. ✓
 - Computers help you to spot problems in advance in the mechanics of the harvester. ✓
 - Helps to identify plant nutrient deficiencies on the land. ✓
 - Helps to identify problem areas in your maize field. ✓
- (Any acceptable answer) (4)
- 5.6 Can be picked by hand/Silage cutter. ✓ (1)
- 5.7
- To work at the lowest fuel cost. ✓
 - To control weeds effectively. ✓
- (2)
- 5.8 5.8.1
- Sturdy construction. ✓
 - Replaceable wearing parts. ✓
 - Rotor housing should close tightly. ✓
 - Size of the hopper feed aperture. ✓
 - After sale service etc
 - Energy source available
- (Any 4) (4)
- 5.8.2
- Vibration/Loose bolt/nuts. ✓
 - Wear. ✓
 - Rust. ✓
- (3)

[40]

QUESTION 6: WATER MANAGEMENT

- 6.1 6.1.1
- To save water. ✓
 - To prevent over irrigation. ✓
 - To prevent under irrigation.
 - To prevent unnecessary crop stress.
 - Prevent soil compaction.
 - Save on energy costs.
 - Create ideal air/water balance in soil. (Any 2) (2)
- 6.1.2
- Tensiometer. ✓
 - Class A evaporation pan. ✓ (2)
 - Moisture probe
- 6.2 6.2.1
- Brush drain. ✓
 - Pole/pipe drain. ✓
 - Stone drain. ✓
 - Mole drain. ✓ (4)
- 6.2.2
- For correct calibrating of the sprayers. ✓
 - Effective scheduling of irrigation. ✓
 - To prevent over-utilisation of water sources. (Any 2) (2)
- 6.2.3 Flow rate = $\frac{\text{Content}}{\text{Time}}$ OR 1000✓✓ litres per hour✓✓
- $$= \frac{8\,000\checkmark}{8\checkmark}$$
- $$= 1\,000\checkmark \text{ litres per hour}\checkmark \quad (4)$$
- 6.3 6.3.1
- Sewage is broken down by anaerobic bacteria in the first tank. ✓
 - Very little solids remain when the watery sewerage flows to the second tank. ✓
 - Only liquid sewage remains and drains away through the outlet pipe or stone trench. ✓ (3)
- 6.3.2
- It can back up. ✓
 - Clog the drainage field. ✓ (2)
- 6.3.3
- Use only toilet paper. ✓
 - No plastics or non-degradable materials. ✓
 - No cigarette butts, rags etc. should get into the tank. ✓
 - No disinfectants should be used. ✓
 - No bleaches and oils. ✓ (5)
- 6.3.4
- Do not build near boreholes, drinking water installations. ✓
 - Not next to the house. ✓
 - Not near traffic. ✓
 - Not near where people eat, wash or work regularly. ✓ (4)

- 6.4
- Bury deep enough not to be damaged by implements. ✓
 - Bury in sand. ✓
 - Couplings must be firm and watertight. ✓
 - A layer of lime should cover the pipeline about 600 mm above the pipe to prevent damaging the pipe at a later stage. (Any 2)

(2)
[30]

TOTAL SECTION B: 160
GRAND TOTAL: 200