



basic education

Department:
Basic Education
REPUBLIC OF SOUTH AFRICA

**NATIONAL
SENIOR CERTIFICATE**

GRADE 12

MECHANICAL TECHNOLOGY

FEBRUARY/MARCH 2013

MARKS: 200

TIME: 3 hours

This question paper consists of 13 pages and a 5-page formula sheet.



INSTRUCTIONS AND INFORMATION

1. Write your centre number and examination number in the spaces provided on the ANSWER BOOK.
2. Read ALL the questions carefully.
3. Answer ALL the questions.
4. Answer QUESTION 1 in the ANSWER BOOK.
5. Number the answers correctly according to the numbering system used in this question paper.
6. Start EACH question on a NEW page.
7. Show ALL calculations and units. Round off final answers to TWO decimal places.
8. Candidates may use non-programmable scientific calculators and drawing instruments.
9. The value of gravitational force should be taken as 10 m/s^2 .
10. All dimensions are in millimetres, unless stated otherwise in the question.
11. Write neatly and legibly.
12. Use the criteria below to assist you in managing your time.

QUESTION	CONTENT COVERED	MARKS	TIME
1	Multiple-choice Questions	20	18 minutes
2	Tools and Equipment	20	18 minutes
3	Materials	20	18 minutes
4	Safety, Terminology and Joining Methods	50	45 minutes
5	Maintenance and Turbines	40	36 minutes
6	Forces, Systems and Control	50	45 minutes
TOTAL		200	180 minutes



QUESTION 1: MULTIPLE-CHOICE QUESTIONS

Various options are provided as possible answers to the following questions. Choose the answer and write the letter (A–D) next to the question number (1.1–1.20) in the ANSWER BOOK, for example 1.21 D.

- 1.1 FIGURE 1.1 below shows the procedure for removing and replacing bearings. Which step in the safe work procedure does the figure show?

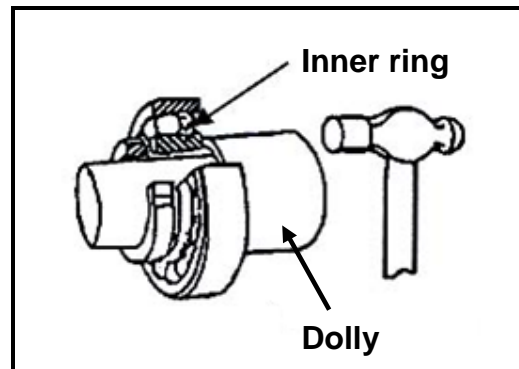

FIGURE 1.1

- A Remove the dolly by driving the tapered point of a screw driver or wedge into the split of the dolly to force it open.
- B Remove the burrs from the shaft to prevent damage to the dolly.
- C Place the driving dolly against the inner ring of the bearing and tap the dolly with a hammer.
- D Slacken the lock nut two or three turns with a spanner. (1)
- 1.2 Which ONE of the following safety procedures relates to the bearing and gear puller?
- A Make sure that the puller is tightened around the component.
- B You may exceed the recommended pressure.
- C Worn-out puller legs may be used.
- D Use a hammer to tighten the puller lever. (1)
- 1.3 What is the function of a valve-spring tester?
- A Test the valve spring for twisting and squareness before installation.
- B Test the valve spring for tension and squareness before installation.
- C Test the valve spring for shearing and squareness before installation.
- D Test the valve spring for deflection and squareness before installation. (1)



- 1.4 The main reason for using a tensile tester is to measure the ...
- A ability of a metal to bend without breaking.
 - B resistance of a metal against elongation when an increasing axial force is applied.
 - C ability of a metal to elongate without breaking.
 - D ability of a metal to shorten without breaking. (1)
- 1.5 What do we call a mixture of copper and zinc?
- A Mixture
 - B Non-ferrous alloy
 - C Compound
 - D Metal (1)
- 1.6 Carbon fibre consists of a combination of ... and suitable bonding.
- A non-ferrous metals
 - B thermoplastic material
 - C ferrous material
 - D reinforcing acrylic material (1)
- 1.7 Identify the type of milling cutter shown in FIGURE 1.2 below.

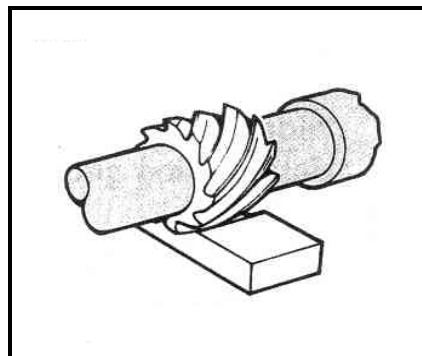

FIGURE 1.2

- A Cylindrical cutter/Helical cutter
- B Equal-angle cutter
- C Convex cutter
- D Single-corner rounding cutter (1)



1.8 Which lathe operation is shown in FIGURE 1.3 below?

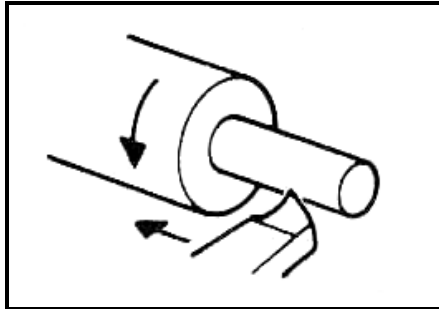

FIGURE 1.3

- A Facing off
- B Thread cutting
- C Parallel turning/Diameter turning
- D Boring/Drilling (1)

1.9 Which THREE indexing methods can be used on a milling machine?

- A Differential, rapid and simple indexing
- B Conventional, simple and differential indexing
- C Conventional, simple and rapid indexing
- D Conventional, simple and angular indexing (1)

1.10 Why is the free-bend test used?

- A To measure the ductility of weld metal
- B To test the skill of a welder
- C To perform a non-destructive test
- D To approve welds to certain standards (1)

1.11 Which ONE of the following is a destructive test?

- A X-ray test
- B Dye penetration test
- C Nick-break test
- D Ultrasonic test (1)

1.12 Compressive stress can be defined or described as an internal force in a material resisting a ...

- A pulling load.
- B shearing load.
- C pulling and shearing load.
- D pushing load. (1)

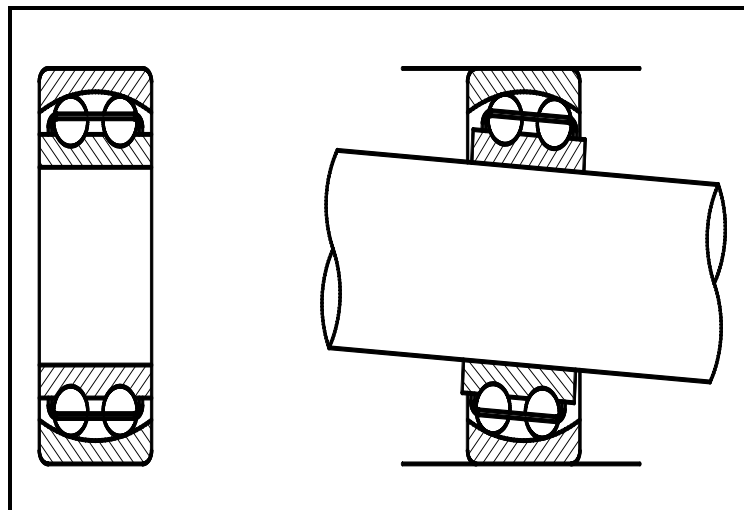

- 1.13 Which ONE of the following is a definition of Hooke's law?
- A The measurement of the extension or contraction of a bar when an external load is applied.
 - B The stress value required to produce unit strain in a tensile specimen of a particular material.
 - C A measurement of the deformation produced by the application of an external force.
 - D Strain is directly proportional to the stress it causes, provided that the limit of proportionality is not exceeded. (1)
- 1.14 What effect will a crossed belt drive have on two pulleys with different diameters?
- A The two pulleys will turn at the same speed.
 - B The two pulleys will cancel each other.
 - C The two pulleys will turn in opposite directions. (1)
 - D The two pulleys will turn in the same direction.
- 1.15 What is the function of the bearing in FIGURE 1.4 below?

**FIGURE 1.4**

- A It supports and aligns the shaft. (1)
- B It increases the rotation frequency of the shaft.
- C It decreases the rotation frequency of the shaft.
- D It rotates the shaft at a low speed.



1.16 What is the gear ratio of the gear system in FIGURE 1.5 below?

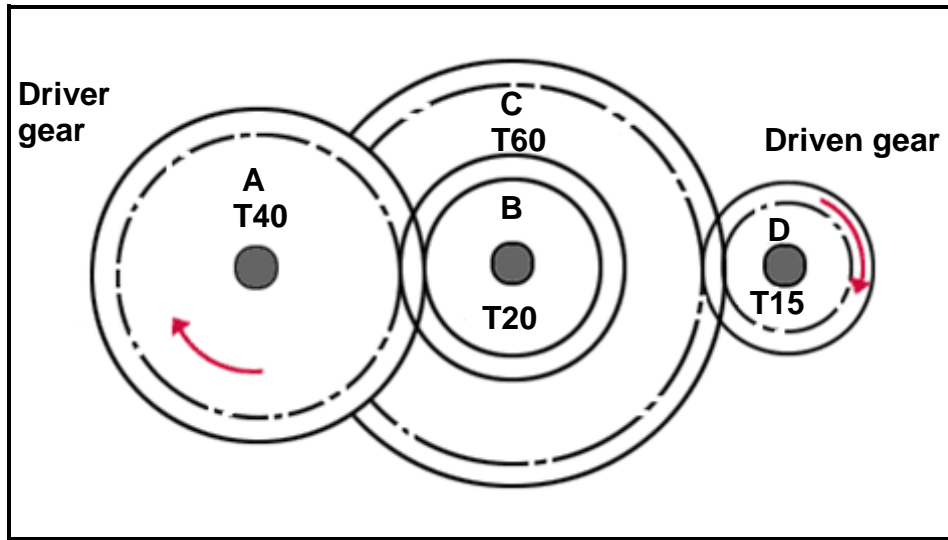

FIGURE 1.5

- A 1 : 4
- B 1 : 8
- C 4 : 1
- D 1 : 2

(1)

1.17 How much force is produced by the piston shown in FIGURE 1.6 below if the air pressure is 0,5 N/mm²?

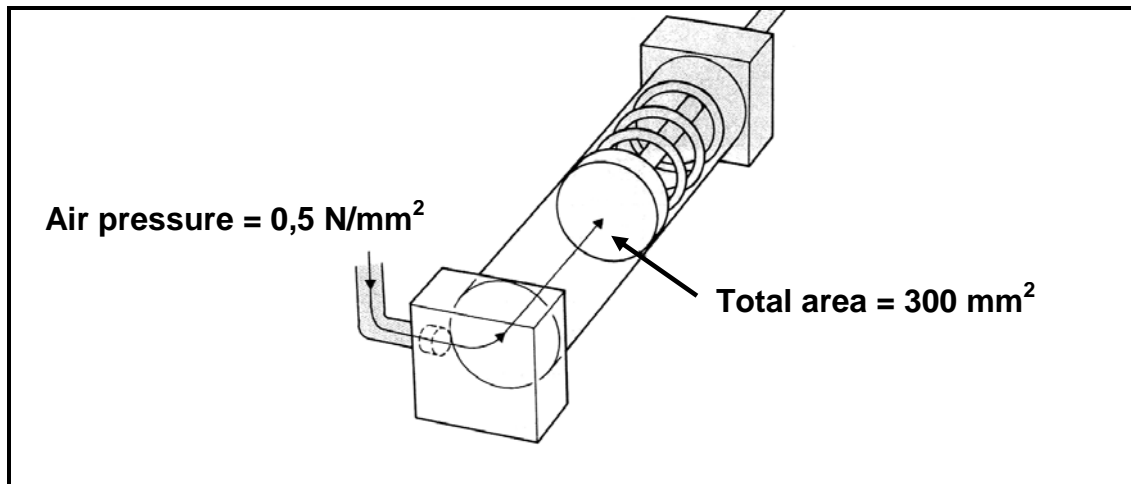

FIGURE 1.6

- A 1 500 N
- B 1,5 N
- C 15 N
- D 150 N

(1)



- 1.18 Which ONE of the gear systems below would be used to change rotary movement to linear movement?
- A Spur gears
 - B Worm shaft and worm gear
 - C Rack and pinion
 - D Ratchet and pawl
- (1)
- 1.19 What do you understand by the term *mechanical efficiency* of a supercharger?
- A How much a positive displacement blower leaks
 - B The ratio of power output to power input
 - C The density of inlet air compared to the density of outlet air
 - D The inlet air pressure compared to the inlet air speed
- (1)
- 1.20 What do you understand by the term *boost* in relation to superchargers?
- A The pressure the supercharger creates in the intake manifold
 - B Where the blower is situated before the carburettor
 - C The centrifugal force of the air to create compression
 - D Where the blower is situated after the carburettor
- (1)
[20]

QUESTION 2: TOOLS AND EQUIPMENT

- 2.1 A gas analyser is used to analyse the exhaust gases of an engine. State the gases that are analysed for complete combustion. (2)
- 2.2 Define the *hardness* of a metal. (2)
- 2.3 Name TWO devices that are used to test the hardness of a metal. (2)
- 2.4 Give THREE reasons for using a compression tester on an engine. (3)
- 2.5 State THREE causes of cylinder leakages in an internal-combustion engine. Also explain how each cause can be determined by using the cylinder leakage tester. (6)
- 2.6 State the function of a tensile tester. (2)
- 2.7 Why does a mechanical engineer need to conduct a bending test on a roof beam? (2)
- 2.8 Write out the abbreviation *MIGS* that is used in welding. (1)
[20]



QUESTION 3: MATERIALS

- 3.1 Give THREE reasons for manufacturing alloys. (3)
- 3.2 State TWO advantages of thermoplastics over thermosetting plastics. (2)
- 3.3 Explain the difference between *tin-base* and *lead-base* in white metal. (2)
- 3.4 Why is flux used during soldering? (1)
- 3.5 Name TWO advantages of silver solder over ordinary soft solder. (2)
- 3.6 Explain why the following materials are used for the given application:
- 3.6.1 PVC (polyvinyl chloride) for insulation and water pipes (2)
- 3.6.2 Copper wire for electrical cables (2)
- 3.7 Give TWO reasons why some materials are used in a liquid state. (2)
- 3.8 Nylon is extensively used in industry today.
- 3.8.1 State TWO properties of nylon. (2)
- 3.8.2 State TWO uses of nylon. (2)
- [20]**

QUESTION 4: SAFETY, TERMINOLOGY AND JOINING METHODS

- 4.1 Name THREE safety precautions to be observed when a tensile tester is used. (3)
- 4.2 Name THREE operational safety precautions to be observed when a multimeter is used. (3)
- 4.3 Which safety precautions should be observed when working on the following parts of a lathe:
- 4.3.1 Chuck (1)
- 4.3.2 Machine guard (1)
- 4.3.3 Tail stock (1)
- 4.4 Matt owns a small workshop that renders mechanical services to the farmers in the vicinity of their small town. Matt receives an order to machine a gear with 97 teeth. Matt has a milling machine in his workshop but does not use it often. Help him by answering the following questions:
- 4.4.1 Which type of milling cutter must he use to machine the gear? (1)



- 4.4.2 Explain, by using a neat labelled sketch, how up-cut milling must be done. (2)
- 4.4.3 Determine, by means of calculations, the indexing needed to cut the gear with 97 teeth. Use $A = 100$ or $N = 100$ and $n = 97$ for your calculations. (4)
- 4.4.4 Determine, by means of calculations, the change gears which must be mounted on the dividing head. (5)
- 4.5 State TWO advantages of helical cutters. (2)
- 4.6 Determine, by means of calculations, the feed in millimetres per minute for a milling machine, using the information below. (3)
- Feed per tooth = 0,04 mm
Number of teeth on the milling cutter = 30
Number of revolutions per minute of the cutter = 400 r/min
- 4.7 The gear set of a simple lathe is shown in FIGURE 4.1 below. Gear **A** rotates at 2 000 revolutions per minute and has 25 teeth, and meshes in with gear **B** which has 50 teeth. Gear **C** has 30 teeth and is on a common shaft with gear **B**. Gear **D** has 60 teeth and is driven by gear **C**. The module for the gears is 2,5.

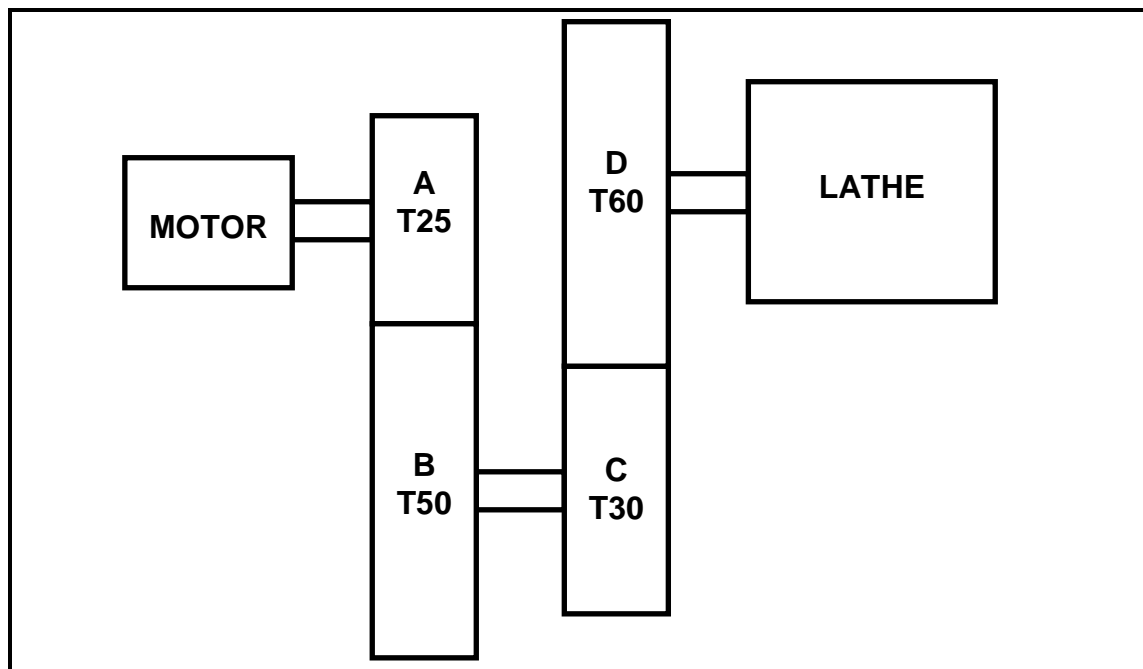

FIGURE 4.1

Calculate the following:

- 4.7.1 The dedendum (2)
- 4.7.2 The gear ratio (3)



- 4.7.3 The pitch circle diameter of gear **A** (3)
- 4.7.4 The outside diameter of gear **A** (2)
- 4.7.5 The circular pitch of the teeth (3)
- 4.8 State **THREE** advantages of MIG/MAG welding. (3)
- 4.9 Piet must determine the quality of all the welding joints at Sarel's welding plant. He saw quite a number of welding flaws and asked you to help him correct it.

Copy the table below and name **ONE** cause of the welding flaw, as well as and **ONE** non-destructive test which can be used to detect the flaw.

WELDING FLAW	ONE CAUSE	NAME ONE NON-DESTRUCTIVE TEST
Cracks		
Poor fusion		
Porosity		
Under-cutting		

(8)
[50]

QUESTION 5: MAINTENANCE AND TURBINES

- 5.1 Define the term *pour point* in relation to fluids. (2)
- 5.2 State **THREE** precautions that should be followed when cutting fluids are used during screw cutting on a lathe. (3)
- 5.3 State **FOUR** maintenance applications when cutting fluid is used on a centre lathe. (4)
- 5.4 Give **TWO** reasons for changing the oil in an engine. (2)
- 5.5 How would you change the oil filter on an engine? (5)
- 5.6 State **FOUR** causes of overheating of bearing. (4)
- 5.7 State the function of a steam turbine. (2)
- 5.8 Name **TWO** classes of turbines. (2)
- 5.9 Explain clearly how a turbocharger works. (6)
- 5.10 State **FOUR** advantages of gas turbines. (4)



- 5.11 What do you understand by the term *turboboost*? (2)
- 5.12 State TWO advantages of a supercharger. (2)
- 5.13 Briefly explain TWO disadvantages of using a supercharger. (2)

[40]**QUESTION 6: FORCES, SYSTEMS AND CONTROL**

- 6.1 A 3,08 m long steel wire with a cross-sectional area of $8,08 \times 10^{-3} \text{ m}^2$ hangs vertically with a 2,5 kN load attached to it. The load causes an increase of 0,391 mm in the length of the wire.

- 6.1.1 Name the type of stress in the wire material. (2)

Determine by means of calculations:

- 6.1.2 The stress in the wire material (3)
- 6.1.3 The strain caused by the load (3)
- 6.1.4 The elasticity modulus for this material (3)

- 6.2 The gear system in FIGURE 6.1 below is used to control a hoisting device. The driver gear has 50 teeth and rotates at 660 r/min. The idler gear, used to change the direction, rotates at 1 000 r/min. The driven gear has 60 teeth.

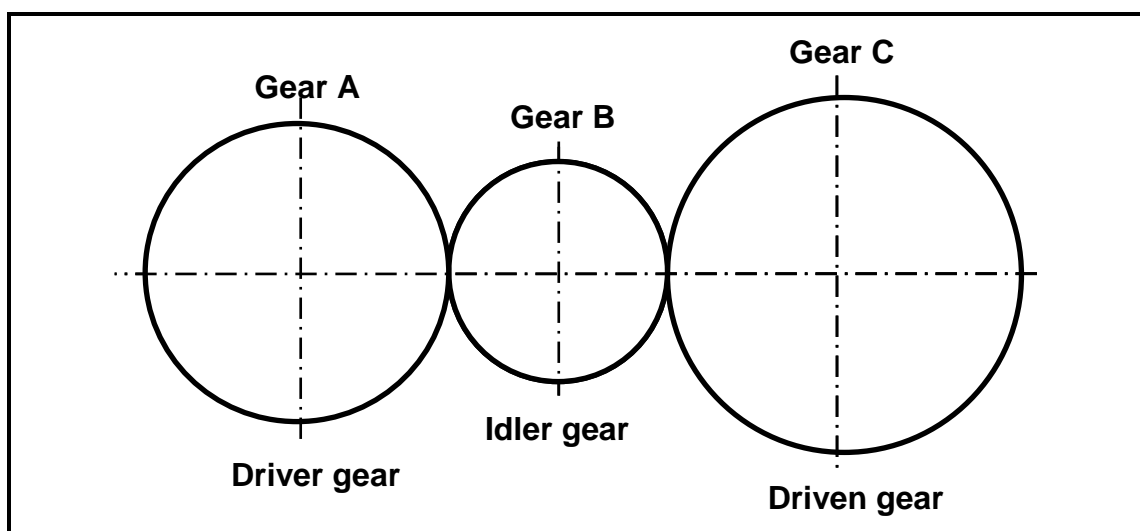
**FIGURE 6.1**

- 6.2.1 Determine, by means of calculations, the number of teeth on the idler gear. (4)
- 6.2.2 Determine, by means of calculations, the rotation frequency of the driven gear. (4)
- 6.2.3 In which direction will the driven gear rotate if the driver gear rotates clockwise? (2)



- 6.3 A water pump needs to rotate at 10 r/s and is driven by a pulley with a diameter of 600 mm that rotates at a speed of 7,2 r/s. The tensile force in the tight side of the belt is 300 N. The ratio of the tensile force in the tight side to the tensile force in the slack side is 2,5 : 1. (The thickness of the belt can be ignored for the calculations.)

Determine by means of calculations:

- 6.3.1 The diameter of the pulley that needs to be fitted on the water pump (4)

- 6.3.2 The power that can be transmitted (6)

- 6.4 A diagrammatical representation of a hydraulic press is shown in FIGURE 6.2 below. The applied force of 0,85 kN on piston A is needed to complete one stroke of 110 mm. The diameter of piston A is 36 mm and the diameter of piston B is 225 mm.

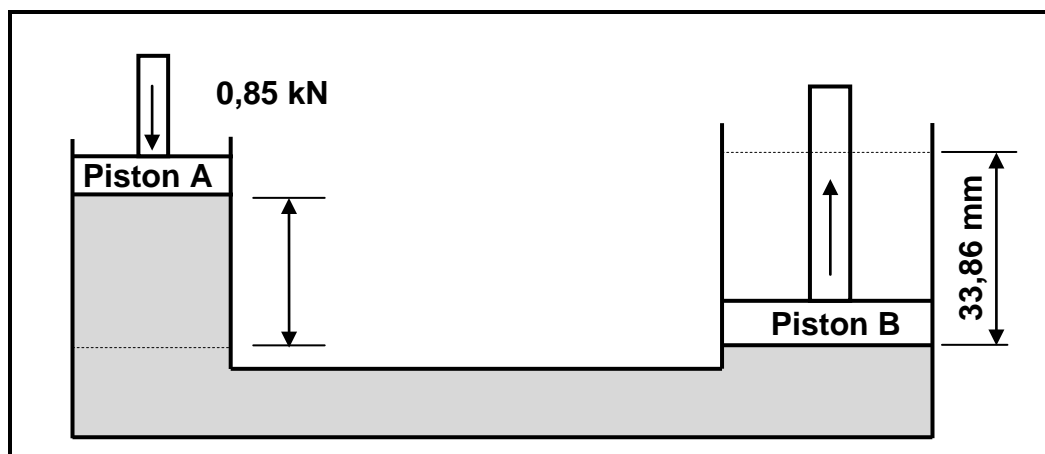

FIGURE 6.2

Determine by means of calculations:

- 6.4.1 The pressure in the system (5)

- 6.4.2 The number of strokes that piston A uses to lift piston B to 33,86 mm. The system has one-way valves to supply it with hydraulic fluid during the process. (9)

- 6.5 A single-plate friction clutch is used to transmit 220 Nm torque in an engine/generator combination. The clutch plate has friction material on both sides. The friction coefficient is 0,4. The total applied force on the pressure plate is 2,8 kN.

Calculate the effective diameter of the clutch plate. (5)
[50]

TOTAL: 200



FORMULA SHEET FOR MECHANICAL TECHNOLOGY – GRADE 12**1. BELT DRIVES**

$$1.1 \quad \text{Belt speed} = \frac{\pi DN}{60}$$

$$1.2 \quad \text{Belt speed} = \frac{\pi (D + t) \times N}{60} \quad (t = \text{belt thickness})$$

$$1.3 \quad \text{Belt mass} = \text{Area} \times \text{length} \times \text{density} \quad (A = \text{thickness} \times \text{width})$$

$$1.4 \quad \text{Speed ratio} = \frac{\text{Diameter of driven pulley}}{\text{Diameter of driver pulley}}$$

$$1.5 \quad N_1 D_1 = N_2 D_2$$

$$1.6 \quad \text{Open-belt length} = \frac{\pi (D + d)}{2} + \frac{(D - d)^2}{4c} + 2c$$

$$1.7 \quad \text{Crossed-belt length} = \frac{\pi (D + d)}{2} + \frac{(D + d)^2}{4c} + 2c$$

$$1.8 \quad \text{Power} (P) = \frac{2 \pi N T}{60}$$

$$1.9 \quad \text{Ratio of tight side to slack side} = \frac{T_1}{T_2}$$

$$1.10 \quad \text{Power} (P) = \frac{(T_1 - T_2) \pi D N}{60} \quad \text{where } T_1 = \text{force in the tight side}$$

$$1.11 \quad \text{Width} = \frac{T_1}{\text{permissible tensile force}}$$



2. FRICTION CLUTCHES

$$2.1 \quad \text{Torque (} T \text{)} = \mu W n R$$

$\mu = \text{coefficient of friction}$
 $W = \text{total force}$
 $n = \text{number of friction surfaces}$
 $R = \text{effective radius}$

$$2.2 \quad \text{Power (} P \text{)} = \frac{2 \pi N T}{60}$$

3. STRESS AND STRAIN

$$3.1 \quad \text{Stress} = \frac{\text{Force}}{\text{Area}} \quad \text{or} \quad \left(\sigma = \frac{F}{A} \right)$$

$$3.2 \quad \text{Strain (} \varepsilon \text{)} = \frac{\text{change in length (} \Delta L \text{)}}{\text{original length (} L \text{)}}$$

$$3.3 \quad \text{Young's modulus (} E \text{)} = \frac{\text{stress}}{\text{strain}} \quad \text{or} \quad \left(\frac{\sigma}{\varepsilon} \right)$$

$$3.4 \quad A_{\text{shaft}} = \frac{\pi d^2}{4}$$

$$3.5 \quad A_{\text{pipe}} = \frac{\pi(D^2 - d^2)}{4}$$

4. HYDRAULICS

$$4.1 \quad \text{Pressure (} P \text{)} = \frac{\text{Force (} F \text{)}}{\text{Area (} A \text{)}}$$

$$4.2 \quad \frac{F_1}{A_1} = \frac{F_2}{A_2}$$

$$4.3 \quad \text{Work done} = \text{force} \times \text{distance}$$

$$4.4 \quad \text{Volume} = \text{Cross-sectional area} \times \text{stroke length (} l \text{ or } s \text{)}$$



5. WHEEL AND AXLE

$$5.1 \quad \text{Velocity ratio (VR)} = \frac{\text{effort distance}}{\text{load distance}} = \frac{2D}{d_2 - d_1}$$

$$5.2 \quad \text{Mechanical advantage (MA)} = \frac{\text{Load (W)}}{\text{Effort (F)}}$$

$$5.3 \quad \text{Mechanical efficiency (} \eta_{\text{mech}} \text{)} = \frac{\text{MA}}{\text{VR}} \times 100\%$$

6. LEVERS

$$6.1 \quad \text{Mechanical advantage (MA)} = \frac{\text{Load (W)}}{\text{Effort (F)}}$$

$$6.2 \quad \text{Input movement (IM)} = \text{Effort} \times \text{distance moved by effort}$$

$$6.3 \quad \text{Output movement (OM)} = \text{Load} \times \text{distance moved by load}$$

$$6.4 \quad \text{Velocity ratio (VR)} = \frac{\text{Input movement}}{\text{Output movement}}$$

7. SCREW THREADS

$$7.1 \quad \text{Pitch diameter} = \text{Outside diameter} - \frac{1}{2} \text{ pitch}$$

$$7.2 \quad \text{Pitch circumference} = \pi \times \text{pitch diameter}$$

$$7.3 \quad \text{Lead} = \text{pitch} \times \text{number of starts}$$

$$7.4 \quad \text{Helix angle: } \tan \theta = \frac{\text{Lead}}{\text{Pitch circumference}}$$

$$7.5 \quad \text{Leading tool angle} = 90^\circ - (\text{helix angle} + \text{clearance angle})$$

$$7.6 \quad \text{Following/Trailing angle} = 90^\circ + (\text{helix angle} - \text{clearance angle})$$

$$7.7 \quad \text{Number of turns} = \frac{\text{height}}{\text{lead}}$$



8. GEAR DRIVES

$$8.1 \quad \text{Power (} P \text{)} = \frac{2 \pi NT}{60}$$

$$8.2 \quad \text{Gear ratio} = \frac{\text{Product of the number of teeth on driven gear}}{\text{Product of the number of teeth on driver gear}}$$

$$8.3 \quad \frac{N_{\text{input}}}{N_{\text{output}}} = \frac{\text{Product of the number of teeth on driven gear}}{\text{Product of the number of teeth on driver gear}}$$

$$8.4 \quad \text{Torque} = \text{force} \times \text{radius}$$

$$8.5 \quad \text{Torque transmitted} = \text{gear ratio} \times \text{input torque}$$

$$8.6 \quad \text{Module (} m \text{)} = \frac{\text{Pitch-circle diameter (} PCD \text{)}}{\text{Number of teeth (} T \text{)}}$$

$$8.7 \quad N_1 T_1 = N_2 T_2$$

$$8.8 \quad \text{Pitch-circle diameter (} PCD \text{)} = \frac{\text{circular pitch (} CP \text{)} \times \text{number of teeth (} T \text{)}}{\pi}$$

$$8.9 \quad \text{Outside diameter (} OD \text{)} = PCD + 2 \text{ module}$$

$$8.10 \quad \text{Addendum (} a \text{)} = \text{module (} m \text{)}$$

$$8.11 \quad \text{Dedendum (} b \text{)} = 1,157 m \quad \text{or} \quad \text{Dedendum (} b \text{)} = 1,25 m$$

$$8.12 \quad \text{Cutting depth (} h \text{)} = 2,157 m \quad \text{or} \quad \text{Cutting depth (} h \text{)} = 2,25 m$$

$$8.13 \quad \text{Clearance (} c \text{)} = 0,157 m \quad \text{or} \quad \text{Clearance (} c \text{)} = 0,25 m$$

$$8.14 \quad \text{Circular pitch (} CP \text{)} = m \times \pi$$



9. CINCINNATI DIVIDING HEAD TABLE FOR THE MILLING MACHINE

<i>Hole circles</i>											
<i>Side 1</i>	24	25	28	30	34	37	38	39	41	42	43
<i>Side 2</i>	46	47	49	51	53	54	57	58	59	62	66

<i>Standard change gears</i>										
24 x 2	28	32	40	44	48	56	64	72	86	100

$$9.1 \quad \text{Simple indexing} = \frac{40}{n} \quad (\text{where } n = \text{number of divisions})$$

9.2 *Change gears:*

$$\frac{Dr}{Dv} = (A - n) \times \frac{40}{A} \quad \text{or} \quad \frac{Dr}{Dv} = \frac{(A - n)}{A} \times \frac{40}{1} \quad \text{or} \quad \frac{Dr}{Dv} = (N - n) \times \frac{40}{N}$$

10. CALCULATIONS OF FEED

$$10.1 \quad \text{Feed } (f) = f_1 \times T \times N$$

Where: f = feed in millimetres per minute

f_1 = feed per tooth in millimetres

T = number of teeth on cutter

N = number of revolutions of cutter per minute

$$10.2 \quad \text{Cutting speed } (V) = \pi \times D \times N$$

Where: D = diameter of the cutter in metres

