



# basic education

Department:  
Basic Education  
**REPUBLIC OF SOUTH AFRICA**

## **NATIONAL SENIOR CERTIFICATE**

**GRADE 12**

**ELECTRICAL TECHNOLOGY**

**FEBRUARY/MARCH 2015**

**MEMORANDUM**

**MARKS: 200**

**This memorandum consists of 14 pages.**

**INSTRUCTIONS TO MARKERS**

1. All questions with multiple answers imply that any relevant, acceptable answer should be considered.
2. Calculations:
  - 2.1 All calculations must show the formula(e).
  - 2.2 Substitution of values must be done correctly.
  - 2.3 All answers **MUST** contain the correct unit to be considered.
  - 2.4 Alternative methods must be considered, provided that the same answer is obtained.
  - 2.5 Where an erroneous answer could be carried over to the next step, the first answer will be deemed incorrect. However, should the incorrect answer be carried over correctly, the marker has to re-calculate the values, using the incorrect answer from the first calculation. If correctly used, the learner should receive the full marks for subsequent calculations.
3. The memorandum is only a guide with model answers. Alternative interpretations must be considered and marked on merit. However, this principle should be applied consistently throughout the marking session at ALL marking centres.

**QUESTION 1: OCCUPATIONAL HEALTH AND SAFETY**

- 1.1 Working on a live system with exposed conductors. ✓  
Working with portable electric equipment that is not insulated correctly. ✓ (2)
- 1.2 Do not touch the person with your bare hands. ✓  
Switch off the supply immediately. ✓  
Use the emergency stop button if the workshop has one. ✓  
Use an insulated item to free the person.  
Apply the correct medical procedure.  
(Any order) (3)
- 1.3 South Africans should be provided the same work ✓ and economic opportunities for capable people without any discrimination due to gender. ✓  
No person should be exposed to sexual harassment irrespective of their gender. (2)
- 1.4 Do all machines have the required guards? ✓  
Are walkways clearly indicated. ✓  
Does the workshop have sufficient lighting? ✓  
Are signage clearly and correctly put up.  
(Answers must relate to preventing accidents to be considered.) (3)
- [10]**

**QUESTION 2: THREE-PHASE AC GENERATION**

- 2.1 For alternators of similar frame size, three phase machines produce more power than single phase machines. ✓  
The same size of machinery is necessary to drive three phase and single phase alternators. ✓  
Three phase alternators can be connected parallel to obtain a combined power.  
For the same amount of energy, three phase power is cheaper to generate than single phase power.  
The phase of a three phase generator can be connected in star to create a neutral point. (2)

2.2

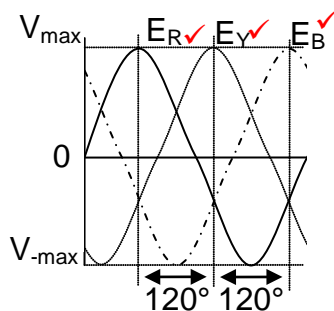

(3)

- 2.3  $P_T = P_1 + P_2$  ✓  
 $= 700 + (-290)$  ✓  
 $= 410W$  ✓ (3)
- 2.4 2.4.1  $I_L = \sqrt{3}I_{Ph}$  ✓  
 $= \sqrt{3} \times 18$  ✓  
 $= 31,18 A$  ✓ (3)
- 2.4.2  $V_{Ph} = \frac{V_L}{\sqrt{3}}$  ✓  
 $= \frac{380V}{\sqrt{3}}$  ✓  
 $= 219,39V$  ✓ (3)
- 2.4.3  $Z_{Ph} = \frac{V_{Ph}}{I_{Ph}}$  ✓  
 $= \frac{219,39}{31,18 A}$  ✓  
 $= 7,04 \Omega$  ✓ (3)
- 2.4.4  $P = \sqrt{3} V_L I_L \cos \theta$  ✓  
 $= \sqrt{3} \times 380 \times 31,18 \times \cos 14^\circ$  ✓  
 $= 19,91 kW$  ✓ (3)
- [20]

**QUESTION 3: THREE-PHASE TRANSFORMERS**

- 3.1 Core type ✓ and  
Shell type ✓ (2)
- 3.2 It improves the insulation of the transformer ✓ and conducts the heat away  
from the windings and core of the cooling surface ✓ (2)
- 3.3 Insufficient ventilation ✓  
Loose connections ✓  
Overloading  
Insulation Breakdown  
Short circuits (2)
- 3.4 Copper losses ✓  
Iron losses ✓ (2)

- 3.5 Bucholtz relay ✓  
Over voltage relay ✓  
Under voltage relay  
Over current relay  
Pressure control device (2)

3.6 3.6.1  $V_L = V_{PH}$  ✓  
 $\therefore V_{PH} = 11kV$  ✓ (2)

3.6.2  $V_L = \sqrt{3} V_{PH}$  ✓  
 $\therefore V_{PH} = \frac{V_L}{\sqrt{3}}$  ✓  
 $= \frac{380}{\sqrt{3}}$   
 $= 219,40V$  ✓ (3)

3.6.3  $\frac{N_p}{N_s} = \frac{V_{PH(P)}}{V_{PH(S)}} \quad \checkmark$   
 $= \frac{11000}{219,40} \quad \checkmark$   
 $\frac{N_p}{N_s} = \frac{50}{1}$   
 $N_p : N_s = 50 : 1 \quad \checkmark$  (3)

- 3.6.4 The voltage ratio shows that the transformer is a step-down transformer (50:1) ✓ The primary current will be lower in the primary winding as compared to the current in the secondary winding for a step down transformer. ✓

Alternative answer:

The power of the transformer remains the same, whether it is calculated on the primary or the secondary side of the transformer. This means that if the voltage decreases from primary to secondary winding (due to the transformer ratio) the current drawn for any specific load will have to increase in the secondary winding as compared to the current drawn from the supply in the primary winding.

$$\frac{V_{ph(p)}}{V_{ph(s)}} = \frac{N_p}{N_s} = \frac{I_{ph(s)}}{I_{ph(p)}}$$

(2)  
[20]

**QUESTION 4: THREE-PHASE MOTORS AND STARTERS**

- 4.1 Stator ✓  
Rotor ✓  
End plates  
Fan  
Frame (2)
- 4.2 They require less maintenance as they do not have as many parts as a single phase motor ✓  
For the same size frame as a single phase motor they deliver a higher torque. ✓ (2)
- 4.3 Power factor ✓  
Voltage rating ✓  
Frequency ✓  
Speed  
Type of connection  
Phase displacement (3)
- 4.4  $V_s = 400 \text{ V}$   
 $F = 60 \text{ Hz}$   
No Poles = 12 poles per phase = 6 pole pairs  
Slip<sub>(Per Unit)</sub> = 0,04
- 4.4.1  $n_s = 60 \times \frac{f}{p}$  ✓  
 $= 60 \times \frac{60}{6}$  ✓  
 $= 600 \text{ rpm}$  ✓ (3)
- 4.4.2  $n_r = n_s (1 - S_{PerUnit})$  ✓  
 $n_r = 600 (1 - 0,04)$  ✓  
 $n_r = 576 \text{ rpm}$  ✓ (3)
- 4.5 It is important to carry out a mechanical inspection to determine before starting if there are any mechanical faults ✓ that may cause damage to the motor or operator on starting. ✓ (2)
- 4.6 Continuity of each winding ✓  
Insulation resistance between each winding ✓  
Insulation resistance between windings and earth  
Exposed windings (2)
- 4.7 The overload relay unit offers protection ✓ to the motor and operator ✓ under fault conditions. ✓ (3)

- 4.8 4.8.1 The function of a star-delta starter is to reduce the starting current of a motor at start-up. ✓ (1)
- 4.8.2 Delta ✓ (1)
- 4.8.3 The retain (hold in) MC<sub>1</sub> is the contact that will keep power on the main contactor when energised. ✓  
The contactor is activated once the start button has been pressed. ✓  
When the start is released power will remain on the main coil through the retain contactor MC<sub>1</sub>. ✓  
MC<sub>1</sub> opens automatically (the contactor is spring loaded) when supply to the coil is removed, thus preventing automatic restarting when power returns after a power failure. (3)
- 4.8.4 When the timer coil is energised the timer will begin to time through.  
Contact T (N/C) will only open ✓ when the timer has timed through a preset time. ✓ (2)
- 4.8.5 Contacts MC<sub>2</sub> (N/C) & MC<sub>3</sub> (N/C) in series with the star and delta contactors are normally closed. ✓  
When MC<sub>2</sub> is energised – MC<sub>2</sub> (N/C) will disconnect MC<sub>3</sub> and prevent it from being accidentally activated. ✓  
While MC<sub>3</sub> is de-energised, MC<sub>3</sub> (N/C) will remain closed, allowing power to be transferred via T(N/C) and MC<sub>3</sub> (N/C) to MC<sub>2</sub> ✓.  
Timer T (N/C) will only transfer power via MC<sub>3</sub> to MC<sub>2</sub> while T is timing through. ✓  
Once T times out and activates, T (N/O) closes and T(N/C) opens. ✓  
MC<sub>2</sub> is deactivated when T(N/C) opens, removing power from it and MC<sub>2</sub> resets ✓ (The contactor is spring loaded).  
When MC<sub>2</sub> resets, MC<sub>2</sub> (N/C) closes and MC<sub>3</sub> is able to be energised through T(N/O) and MC<sub>2</sub> (N/C) which is now closed.  
This energises MC<sub>3</sub> which in turn opens MC<sub>3</sub> (N/C) thus preventing MC<sub>2</sub> from being energised. (6)
- 4.9 4.9.1  $P = \sqrt{3} \times V_L \times I_L \times \cos \theta \times \eta$  ✓  
 $= \sqrt{3} \times 380 \times 12 \times 0,8 \times 0,9$  ✓  
 $= 5,69 \text{ kW}$  ✓ (3)
- 4.9.2 The active power of the motor will increase. ✓ (1)
- 4.9.3  $I_L = \sqrt{3} I_{PH}$  ✓ (1)
- 4.9.4 If the power factor of the motor is improved the motor will draw a lower current ✓ as it will still deliver the same output power. ✓ (2)
- [40]**

**QUESTION 5: RLC**

- 5.1 Connect an ammeter in the circuit ✓ and adjust the frequency of the power supply ✓ until the reading on the ammeter is at a maximum. ✓

**OR**

Connect a volt meter across the coil and capacitor and then adjust the frequency of the power supply until the readings on the two meters are the same.

**OR**

Connect a volt meter across the supply and resistor and then adjust the frequency of the power supply until the readings on the two meters are the same.

(3)

- 5.2 Install a power factor correcting capacitor ✓  
Make use of synchronous motors

(1)

- 5.3 When the frequency is decreased,  $X_L$  will decrease and  $X_C$  will increase. ✓  
 $I_{X_L}$  will then increase and  $I_{X_C}$  will decrease. ✓  
 $I_Z$  will increase as the phase angle changes. ✓

Alternative answer:

At resonance  $X_L = X_C$  and the resultant current in the circuit  $I_Z = I_R$  and this current is in phase with the supplied voltage.

When the supply frequency is reduced the circuit will move out of resonance. Lowering the supply frequency will cause the inductive reactance  $X_L$  to decrease, thus increasing  $I_{X_L}$

Lowering the supply frequency will cause the capacitive reactance  $X_C$  to increase, thus reducing  $I_{X_C}$ .

The circuit will now become increasingly inductive and the resultant current will be lagging with respect to the supply voltage.

As  $I_{X_L}$  and  $I_{X_C}$  oppose each other the resultant reactance will change thus altering the phase angle, resulting in an increase in the current drawn from the supply.

(3)

5.4 5.4.1 
$$f_r = \frac{1}{2\pi\sqrt{LC}} \quad \checkmark$$

$$= \frac{1}{2\pi\sqrt{(0,2 \times 10^{-3}) \times (160 \times 10^{-6})}} \quad \checkmark$$

$$= 890,15 \text{ Hz} \quad \checkmark$$

(3)

5.4.2 
$$I = \frac{V}{Z} \quad \checkmark$$

At resonance  $Z=R$

$$= \frac{240}{30} \quad \checkmark$$

$$= 8 \text{ A} \quad \checkmark$$

(3)



$$\begin{aligned}
 5.4.3 \quad Q &= \frac{X_L}{R} && \checkmark \\
 &= \frac{2\pi fL}{R} && \checkmark \text{ Calculation of } X_L \checkmark \\
 &= \frac{2 \times \pi \times 889 \times 0,2 \times 10^{-3}}{30} \\
 &= 0,04 && \checkmark \quad (4)
 \end{aligned}$$

$$\begin{aligned}
 5.4.4 \quad f_r &= \frac{1}{2\pi\sqrt{LC}} \\
 C &= \frac{1}{4\pi^2 f_r^2 L} && \checkmark \\
 &= \frac{1}{4 \times \pi^2 \times 1000^2 \times 0,2 \times 10^{-3}} && \checkmark \\
 &= 126,6 \mu F && \checkmark
 \end{aligned}$$

(3)  
**[20]**

**QUESTION 6: LOGIC**

- 6.1 6.1.1 The interface is the connection (platform) ✓ between real world devices ✓ and the CPU (controller) ✓. This allows for level conversion of the input information rendering it suitable to be fed into the PLC solid state processor. (3)
- 6.1.2 Relay contacts ✓  
Pushbuttons ✓  
Limit switches  
Analogue sensors  
Selector switches  
(Any TWO) (2)
- 6.1.3 L.E.Ds ✓  
Power Transistors ✓  
Thyristors  
(Any TWO) (2)

- 6.1.4 STEP 1- check input status✓ – the controller examines the status of the input devices and checks whether it is at a 'HIGH' or 'LOW' , '0' OR '1' ✓
- STEP 2- EXECUTE THE PROGRAM-✓ the PLC executes the program one instruction at a time and will store the results as parameters for making further decisions when continuing the scan cycle. ✓
- STEP 3- UPDATE OUTPUT STATUS-✓ the PLC then changes the output according to its programmed instruction list, ladder logic program or logic block diagram(LBD) ✓

(6)

6.2 6.2.1

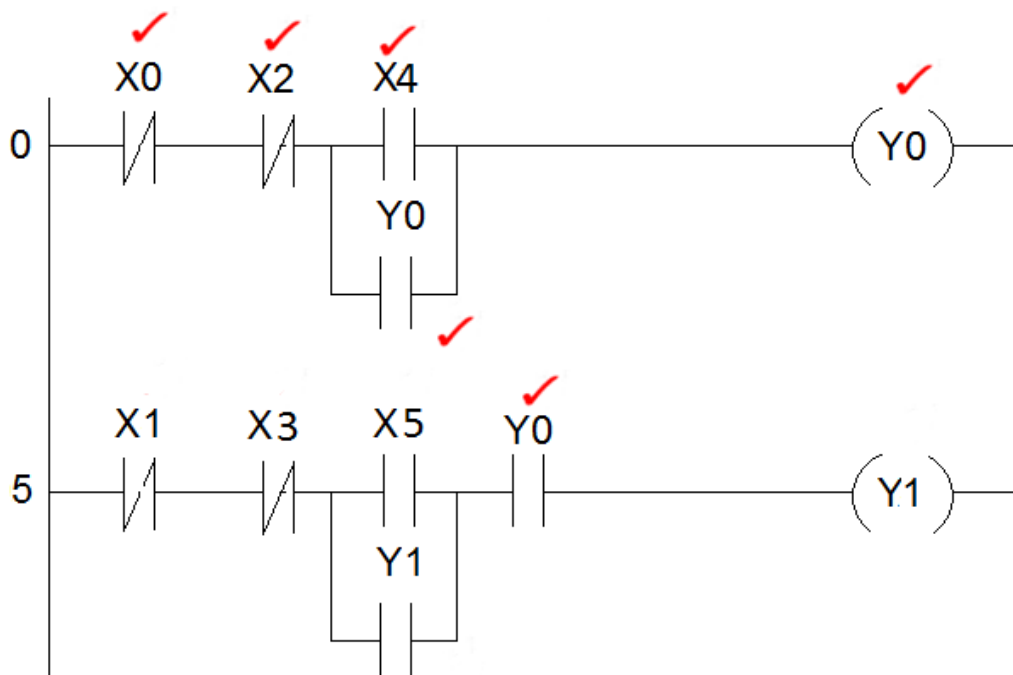

(6)

6.2.2

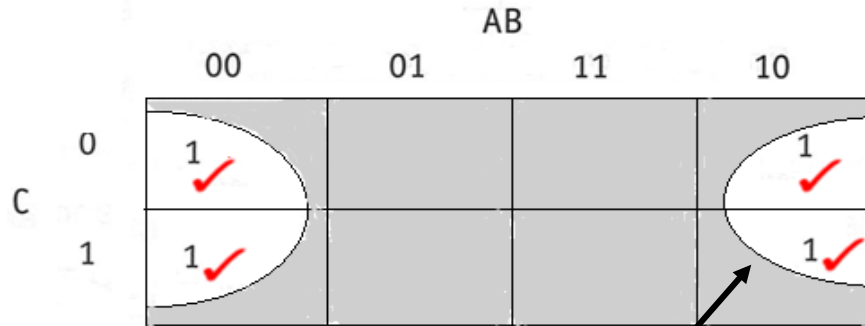

$X = \bar{B}$  ✓

Grouping ✓

(6)

6.2.3

$$\begin{aligned}
 X &= \bar{A}\bar{B}\bar{C} + A\bar{B}\bar{C} + A\bar{B}C + \bar{A}\bar{B}C \\
 &= (\bar{A}\bar{B}\bar{C} + A\bar{B}\bar{C}) + (A\bar{B}C + \bar{A}\bar{B}C) \\
 &= \bar{B}\bar{C}(\bar{A} + A) + \bar{B}C(A + \bar{A}) \\
 &= \bar{B}\bar{C} + \bar{B}C \\
 &= \bar{C}(B + \bar{B}) \\
 &= \bar{C}
 \end{aligned}$$

(7)

6.2.4 The Set/Reset function can be used in motor control ✓  
 The reset function takes priority over the set function ✓  
 This could be used to simulate the start and stop function of a direct-on-line-starter (or any other type of starter). ✓  
 (Any acceptable example other than this must be considered)

(3)

6.2.5 An external Stop Button provides the operator with a physical means of disconnecting supply to the No Volt Coil. ✓  
 On a PLC system the Start and Stop functions can be programmed into the memory as Set Reset functions. ✓  
 This programming function would then in turn enable starting and stopping of the motor. ✓  
 If the output contactor developed a fault and remained in an ON position the operator would lose control of the system,  
 An external Stop button will serve as additional safety and will stop the motor to prevent an accident.

(3)

6.3 Contacts activate after a pre-set time. ✓✓

(2)  
[40]

**QUESTION 7: AMPLIFIERS**

- 7.1 A 741 op-amp is an integrated circuit ✓ which is a circuit that consists of many electronic components ✓ situated on a silicon wafer chip. ✓  
The chip is placed in dual in line package which allows for connection in different modus.

**OR**

An op-amp is an integrated circuit that consists of many electronic components with a high voltage gain when connected to a DC-voltage source. (3)

- 7.2 Infinite bandwidth means that the op-amp can amplify ✓ an input signal over a range of infinite frequencies. ✓ (2)

- 7.3 Open loop voltage gain is infinite ✓  
Input impedance is infinite ✓  
Output impedance is zero  
Unconditional stability (2)

- 7.4 7.4.1 Negative feedback is when a portion of the output signal ✓ is fed back to the input signal. ✓  
It is 180° out of phase with the input signal. ✓  
It is therefore subtracted from the input signal.  
If not controlled negative feedback could attenuate the output to zero. (3)

- 7.4.2 Positive feedback is when a portion of the output signal ✓ is fed back to the input signal ✓  
The feedback is in phase with the input signal ✓  
It is therefore added to the input signal thus increasing the output signal value. ✓  
if not controlled positive feedback could lead to run away, making the circuit unstable. (3)

- 7.5 The bandwidth is increased. ✓  
The level of noise (hiss) is decreased ✓  
The gain is decreased  
The deformation of the input signal is reduced (Any TWO) (2)

- 7.6 Output must show  
Amplification ✓  
Same frequency ✓  
Correct phase ✓  
The input and output frequency must relate/be the same

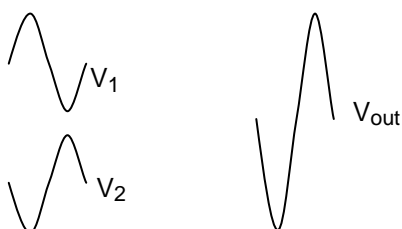
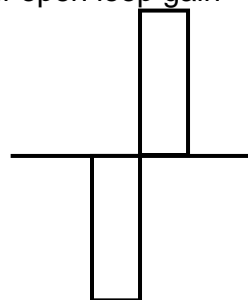
**OR**If open loop gain =  $\infty$ 

(3)

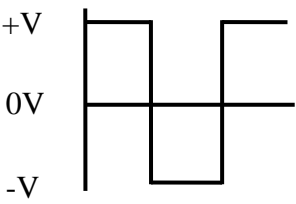
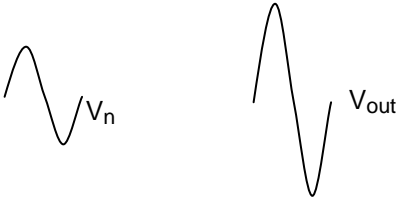
- 7.7 7.7.1  Output must show  
No inversion ✓  
Square wave ✓  
At saturation points ✓ (3)
- 7.7.2 Zero level detector ✓  
Threshold detector (1)
- 7.8 7.8.1 Non-inverting op amp ✓ (1)
- 7.8.2  Non inverted output must show  
Amplification ✓  
Same frequency ✓ (2)
- 7.8.3 
$$A_v = 1 + \frac{R_f}{R_{in}} \quad \checkmark$$

$$= 1 + \frac{12\,000}{3\,000} \quad \checkmark$$

$$= 5 \quad \checkmark$$
 (3)
- 7.8.4 
$$A_v = \frac{V_{out}}{V_{in}} \quad \checkmark$$

$$V_{out} = A_v \times V_{in} \quad \checkmark$$

$$= 5 \times 3 \quad \checkmark$$

$$= 15\text{ V} \quad \checkmark$$
 (3)
- 7.8.5 The value of R<sub>f</sub> determines how much feedback is obtained. If the value of R<sub>f</sub> was decreased the amount of negative feedback obtained is increased. ✓  
The result is that the voltage gain of the circuit will be decreased. ✓ (2)
- 7.8.6 The inverting terminal is connected via R<sub>in</sub> to the 0 V rail ✓ therefore the value of R<sub>in</sub> sets the voltage at that input. ✓ (2)
- 7.9 As a buffer between stages ✓ to provide impedance matching from one stage to the other of an amplifier circuit. ✓ (2)

7.10 7.10.1

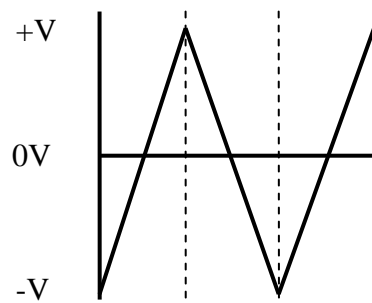

Output must show  
Triangular waveform ✓  
+V ✓  
-V ✓

(3)

7.10.2  $R_{in}$  and C form a time constant ✓ which controls the rate at which the output voltage increases ✓ which determines the time the voltage reaches saturation. ✓

(3)

7.11 7.11.1 Hartley oscillator ✓

(1)

$$\begin{aligned}
 7.11.2 \quad L &= L_1 + L_2 && \checkmark \\
 &= 0,035 + 0,035 && \checkmark \\
 &= 0,07 \text{ H} && \checkmark
 \end{aligned}$$

$$\begin{aligned}
 Fr &= \frac{1}{2\pi\sqrt{LC}} && \checkmark \\
 &= \frac{1}{2\pi\sqrt{0,07 \times 0,47 \times 10^{-6}}} && \checkmark \\
 &= 877,89 \text{ Hz} && \checkmark
 \end{aligned}$$

(6)  
[50]

**TOTAL: 200**