



basic education

Department:
Basic Education
REPUBLIC OF SOUTH AFRICA

**NATIONAL
SENIOR CERTIFICATE**

GRADE 12

ENGINEERING GRAPHICS AND DESIGN P1
FEBRUARY/MARCH 2013

MARKS: 100

TIME: 3 hours



This question paper consists of 6 pages.



INSTRUCTIONS AND INFORMATION

1. This question paper consists of FOUR questions.
2. Answer ALL the questions.
3. ALL drawings are in first-angle orthographic projection, unless otherwise stated.
4. ALL drawings must be completed using instruments, unless otherwise stated.
5. ALL answers must be drawn accurately and neatly.
6. ALL the questions must be answered on the QUESTION PAPER as instructed.
7. ALL the pages must be re-stapled in numerical sequence, irrespective of whether the question was attempted.
8. Time management is essential in order to complete all the questions.
9. Print your examination number in the block provided on every page.
10. Any details or dimensions not given must be assumed in good proportion.

FOR OFFICIAL USE ONLY										
QUESTION	MARKS OBTAINED			½	SIGN	MODERATED			½	SIGN
1										
2										
3										
4										
TOTAL										
	2	0	0			2	0	0		

FINAL CONVERTED MARK	CHECKED BY
100	

COMPLETE THE FOLLOWING:
CENTRE NUMBER
CENTRE NUMBER
EXAMINATION NUMBER
EXAMINATION NUMBER



LAND SURVEYOR'S CERTIFICATE OF THE SIDE LENGTHS AND CORNER HEIGHTS ON STAND 753 PRIME CIRCLE ATHLONE. SURVEYED ON 16-09-2012

LENGTHS IN METRES	HEIGHTS IN METRES
AB = 30,885	A = 66,5
BC = 22,452	B = 65,9
CD = 40,729	C = 64,3
DE = 40,695	D = 64,8
EA = 28,825	E = 65,2

NOTE:

Contractors must verify all dimensions and levels on site before commencing work. Architects to be notified immediately of any discrepancies.

20. In the space provided below, draw, in neat freehand, the front view and top view of the SABS 0143 convention for a kitchen sink.

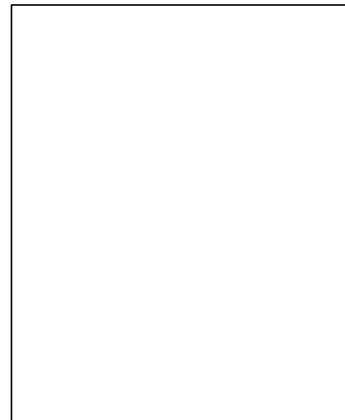

ARCHITECT'S SIGNATURE

CLIENT'S SIGNATURE

REVISION	DATE	DESCRIPTION
2	30-10-2012	ADD PERIMETER WALL
1	23-10-2012	MOVE POOL

PROJECT
PROPOSED NEW DWELLING FOR M PETERSEN ON STAND 753 AT 54 PRIME CIRCLE ATHLONE.

PRINTED BY
PERFECT PRINT

DATE OF PRINT
12-12-2012

DRAWING TITLE
SITE PLAN

PROJECT NUMBER 65-3	DRAWN BY PIETER	DATE 14-10-2012
REFERENCE CODE DBE-2012-01	CHECKED BY THANDI	DATE 14-10-2012
DRAWING NUMBER 1 OF 8	PASSED BY CRAIG	DATE 14-10-2012

THE DESIGN TEAM ARCHITECTS
15 WATERKANT STREET
CAPE TOWN
TEL: 021 555 3434

QUESTION 1: ANALYTICAL (CIVIL)

Given:

A site plan for a new dwelling and swimming pool, a title panel and a table of questions. The drawing has not been prepared to the indicated scale.

Instructions:

Complete the table below by neatly answering the questions, which all refer to the accompanying drawing and title panel. **[30]**

QUESTIONS		ANSWERS	
1	On what date was the site plan printed?	1	
2	Who checked the drawing?	1	
3	How many revisions have been made to the drawing?	1	
4	How wide is the driveway?	1	
5	What is the fall of the sewerage line?	1	
6	How high is the perimeter wall of the stand?	1	
7	In what colour must a new dwelling on a site plan be presented?	1	
8	How deep is the municipal sewerage connection?	1	
9	Name the feature at 1.	1	
10	Name the feature at 2.	1	
11	What does the line at 3 indicate?	1	
12	Name the line at 4.	1	
13	Name the line at 5.	1	
14	What elevation of the new dwelling faces the servitude?	2	
15	Which is the lowest corner on the stand?	2	
16	What is the shortest distance between the dwelling and the pool?	2	
17	With reference to the sewerage, identify and give the reason why the plan could not be approved.	2	
18	Determine the length of the perimeter wall in metres. Show ALL calculations.	3	
19	Determine the total area of the new dwelling in square metres. Show ALL calculations.	3	
20	In the space provided in the title panel, draw, in neat freehand, the front view and top view of the SABS 0143 convention for a kitchen sink.	3	
TOTAL		30	

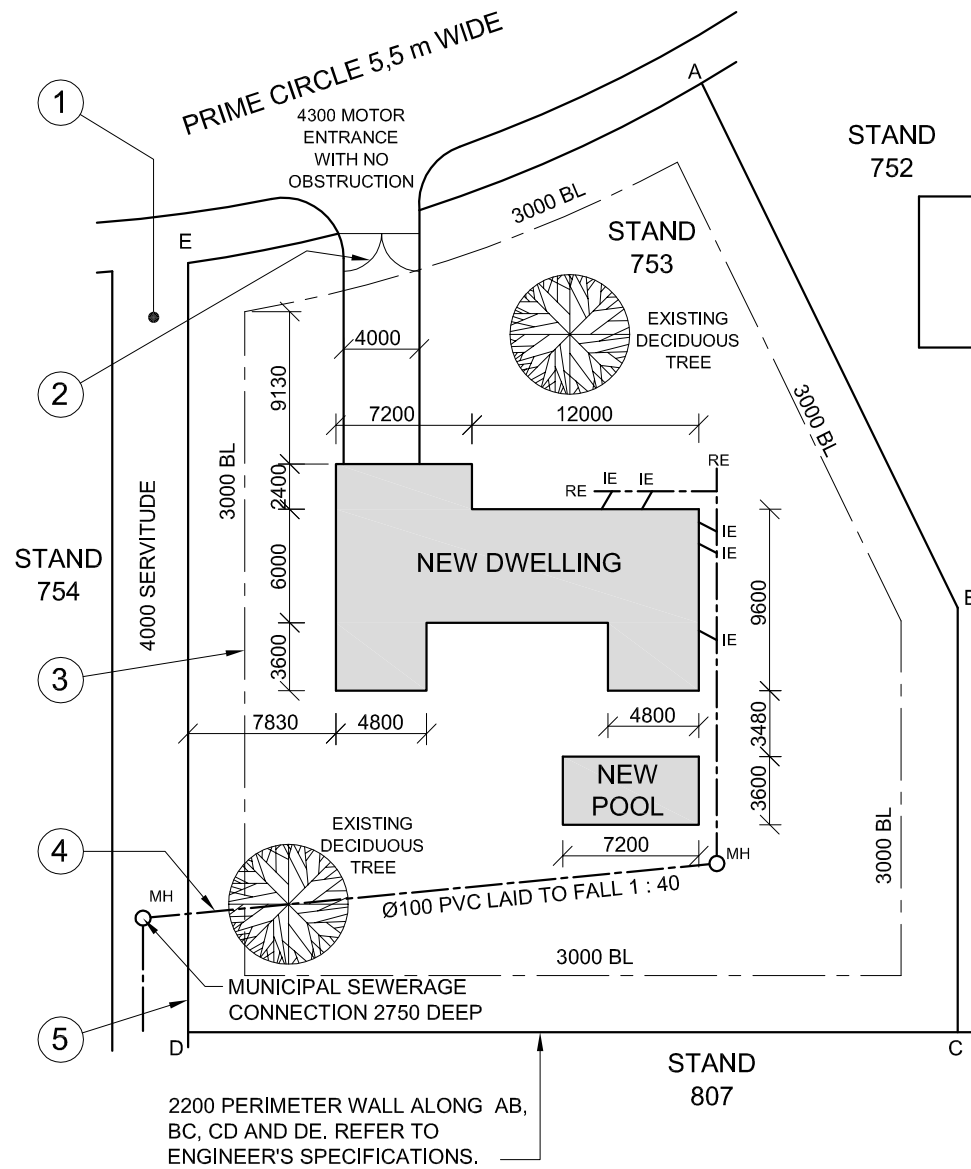

SITE PLAN
SCALE 1 : 150



EXAMINATION NUMBER

EXAMINATION NUMBER

2



QUESTION 2: INTERPENETRATION AND DEVELOPMENT

Given:

- The incomplete front view, right view and top view of a regular square prism that has been shaped to fit around a right regular pentagonal prism. The axes of both prisms lie in a common vertical plane.
- The position of point A.

Instructions:

Draw, to scale 1 : 1, the following views of the TWO prisms:

- 2.1 The given top view
- 2.2 The given right view
- 2.3 The complete front view, clearly showing the curve of interpenetration
- 2.4 Develop the surface of the square prism.

Show ALL hidden detail and fold lines. **[37]**

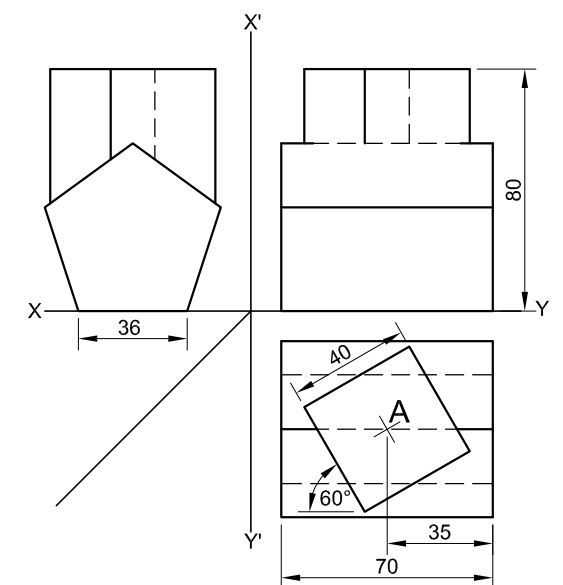

A

ASSESSMENT CRITERIA			
1	TOP VIEW	7	
2	RIGHT VIEW	8	
3	FRONT VIEW	13	
4	DEVELOPMENT	9	
TOTAL		37	
EXAMINATION NUMBER			
EXAMINATION NUMBER			3



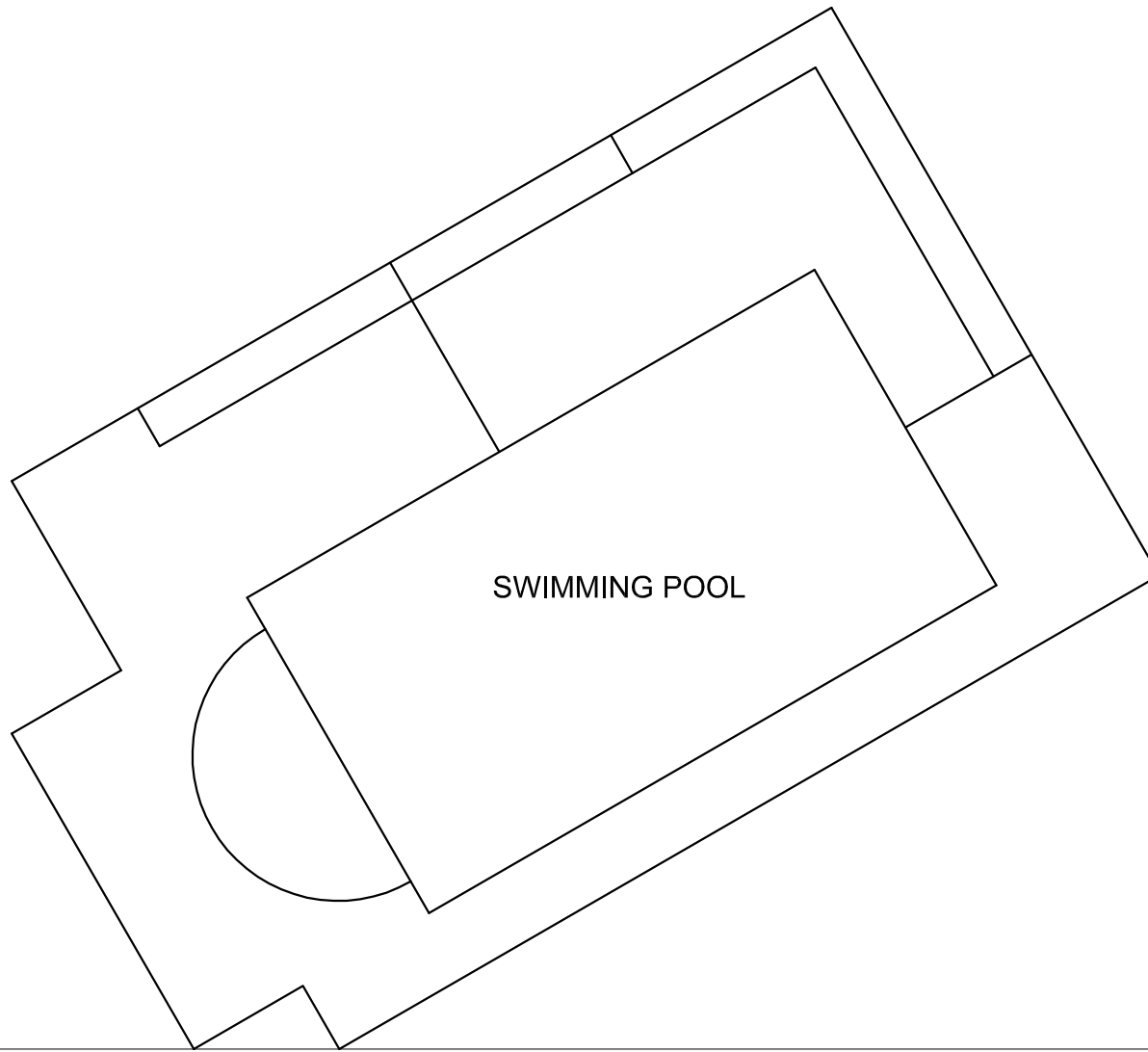

QUESTION 3: PERSPECTIVE

Given:

Two views of an entertainment area and swimming pool and the information needed to draw a two-point perspective drawing.

PP – Picture plane

HL – Horizon line

GL – Ground line

SP – Station point

Instructions:

Complete the perspective drawing.

- Align the drawing sheet with the ground line (GL).
- Determine and label the vanishing points.
- Show ALL necessary construction.
- NO hidden detail is required. **[39]**

PP

HL

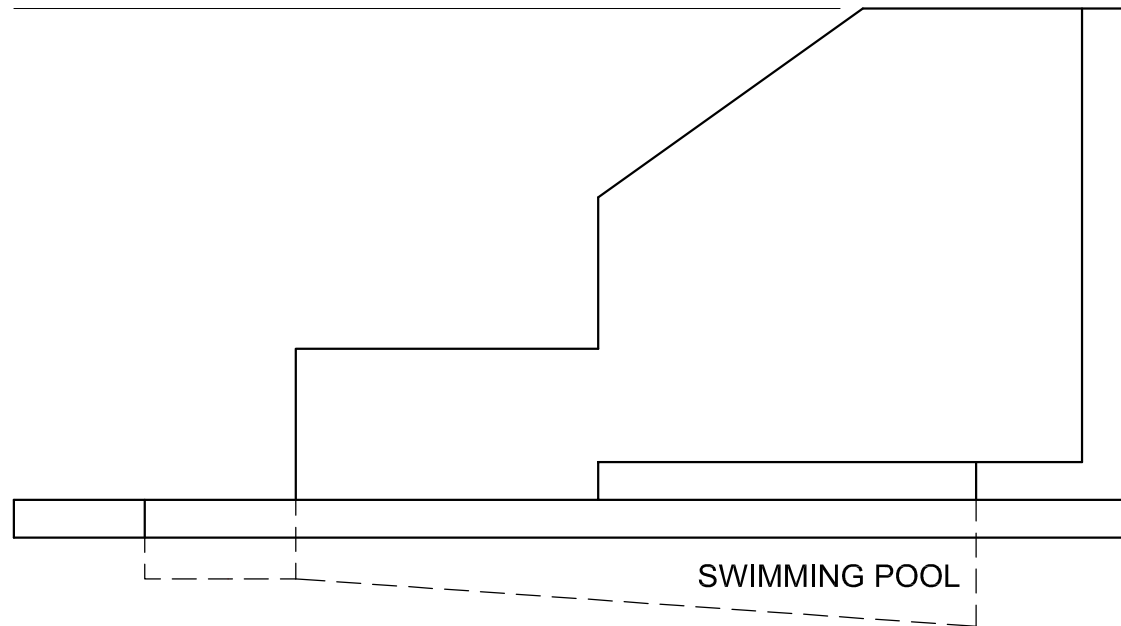

GL

SP

ASSESSMENT CRITERIA			
1	CONSTRUCTION + VPs	6	
2	SURROUND	9½	
3	WALL + STEP	12	
4	SWIMMING POOL	7	
5	SEMI-CIRCLE	4½	
TOTAL		39	
EXAMINATION NUMBER			
EXAMINATION NUMBER			4



DOOR AND WINDOW SCHEDULE

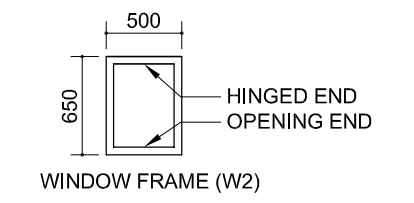
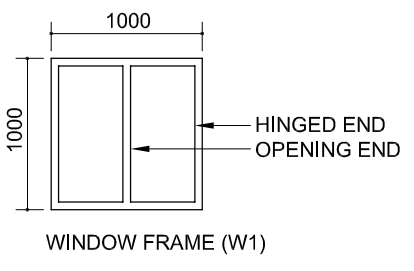
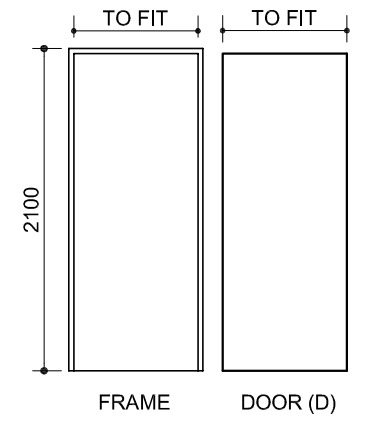

NOTE:
150 x 20 FIBRE CEMENT SILL UNDER ALL WINDOWS

ROOF COMPONENTS

	ROOF CAP
	115 x 38 WALL PLATE
	75 x 50 PURLINS
	100 x 100 GUTTER

DIMENSIONS OF FIXTURES

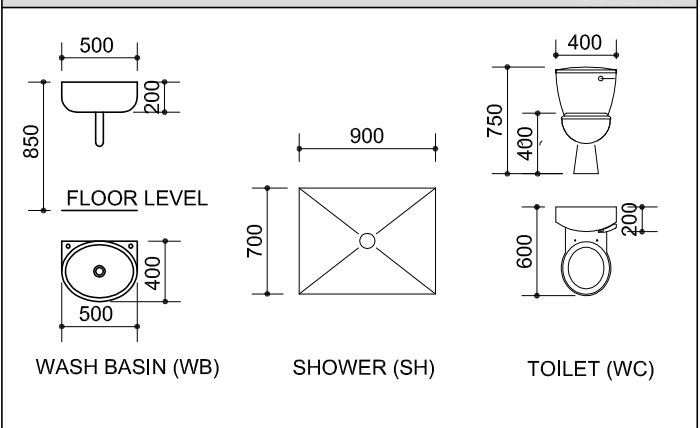

ELECTRICAL SYMBOLS

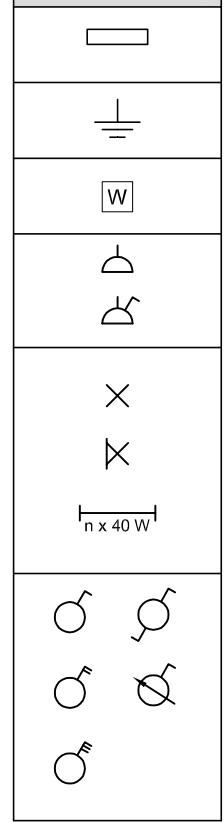

RAINWATER DOWNPIPE

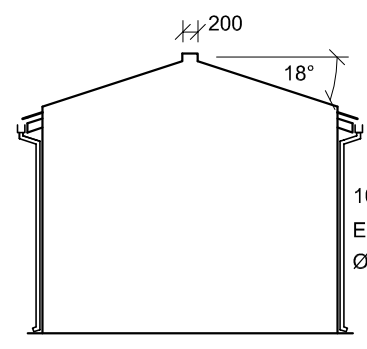
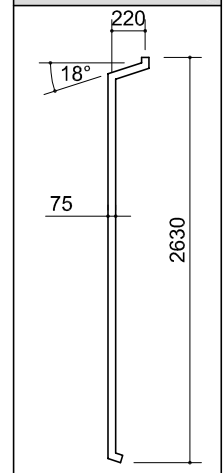

EAST ELEVATION

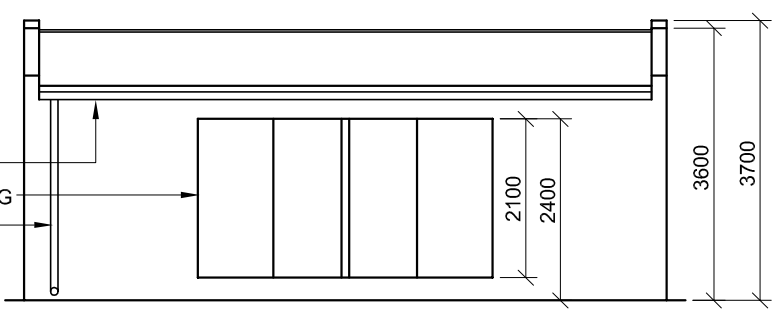

INCOMPLETE SOUTH ELEVATION

- FEATURES**
D DOOR
W1 WINDOW
W2 WINDOW

- FIXTURES**
WC - TOILET
SH - SHOWER
WB - WASH BASIN

- ELECTRICAL FITTINGS**
 1. LIGHT SWITCH ONE-POLE
 2. LIGHT SWITCH TWO-POLE
 3. CEILING LIGHT
 4. SWITCHED SOCKET OUTLET
NOTE:
THE ARROW SHOWS THE LIGHT CONNECTION TO THE SWITCH.

ROOF NOTES:
 ROOF COVER 15 mm FIBRE CEMENT SHEET ON 75 x 50 mm PURLINS @ 700 mm c/c

115 x 38 mm ROOF TRUSS ON 115 x 38 mm WALL PLATE

ROOF PITCH 18°

100 mm SQUARE GUTTER ON BOTH ENDS

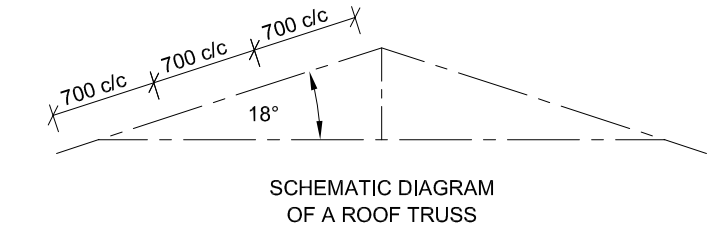

SCHEMATIC DIAGRAM OF A ROOF TRUSS

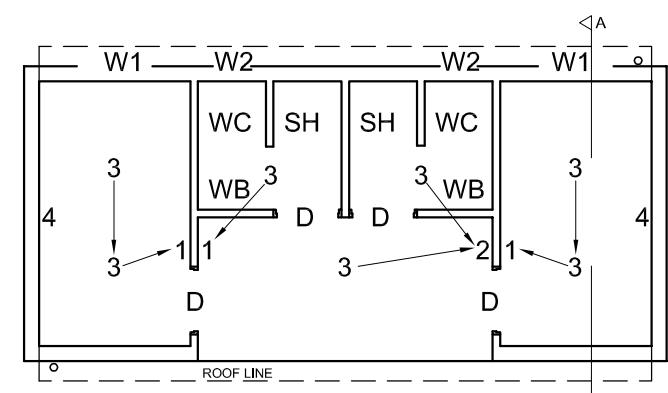

INCOMPLETE FLOOR PLAN

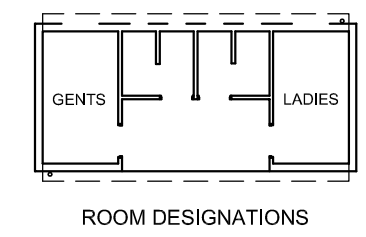

ROOM DESIGNATIONS

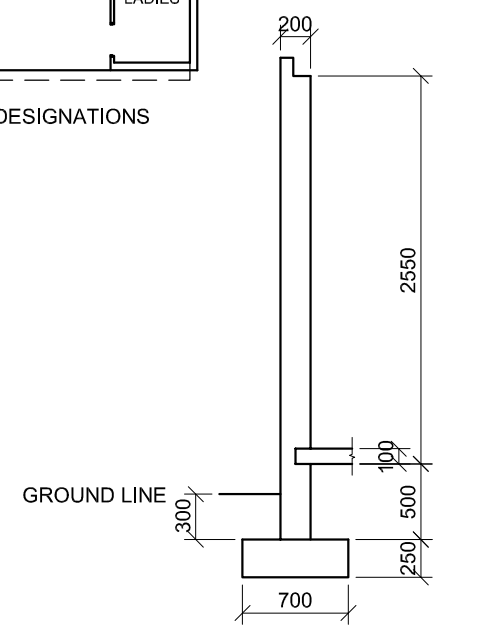

INCOMPLETE FOUNDATION, SLAB AND WALL DETAIL ON A-A

QUESTION 4: CIVIL DRAWING

Given:

- The incomplete south elevation of a new **change room**, showing the walls, the entrance opening, the roof and notes
- The incomplete floor plans showing the walls, position of the doors, the windows, the fixtures, the electrical features and room designations
- The complete east elevation
- Roof notes and a schematic diagram of a roof truss
- The incomplete foundation, slab and wall detail
- A door and window schedule
- A table of electrical symbols
- A table of roof components and the rainwater downpipe
- A table of fixtures
- The incomplete plan of the new **change room**, drawn to scale 1 : 50, on page 6

Instructions:

- Answer this question on page 6.
- Using the given incomplete floor plan, draw in first-angle orthographic projection and to scale 1 : 50, the following views of the new **change room**:
4.1 The complete floor plan
4.2 The south elevation
4.3 A sectional elevation on cutting plane A-A
- ALL drawings must comply with the **guidelines** and **conventions** contained in the *SABS 0143*.

SPECIFICATIONS:

- THE FLOOR PLAN**
Add the following features to the drawing:
- ALL doors and windows
 - ALL fixtures as indicated by the abbreviations
 - ALL electrical fittings as indicated by the numbers
 - ALL hatching detail
- THE SOUTH ELEVATION**
Show the following features on the drawing:
- The outside walls
 - The roof detail, including the gutter and rainwater down-pipe
 - The shower detail with the doors open
 - The finished floor level

- THE SECTIONAL ELEVATION**
Show the following features on the drawing:
- The complete foundation, wall, slab and roof detail
 - The window detail with a double lintel above the window
 - ALL features to the west of cutting plane A-A
 - ALL hatching detail

- Label the following:**
- The room designations and floor finish (tile)
 - The south elevation and the sectional elevation
 - Using the correct abbreviations, label the following features in the correct view: ground level, finished floor level and damp-proof course.
- NOTE:**
 • ONLY the substructure hatching may be drawn in freehand.



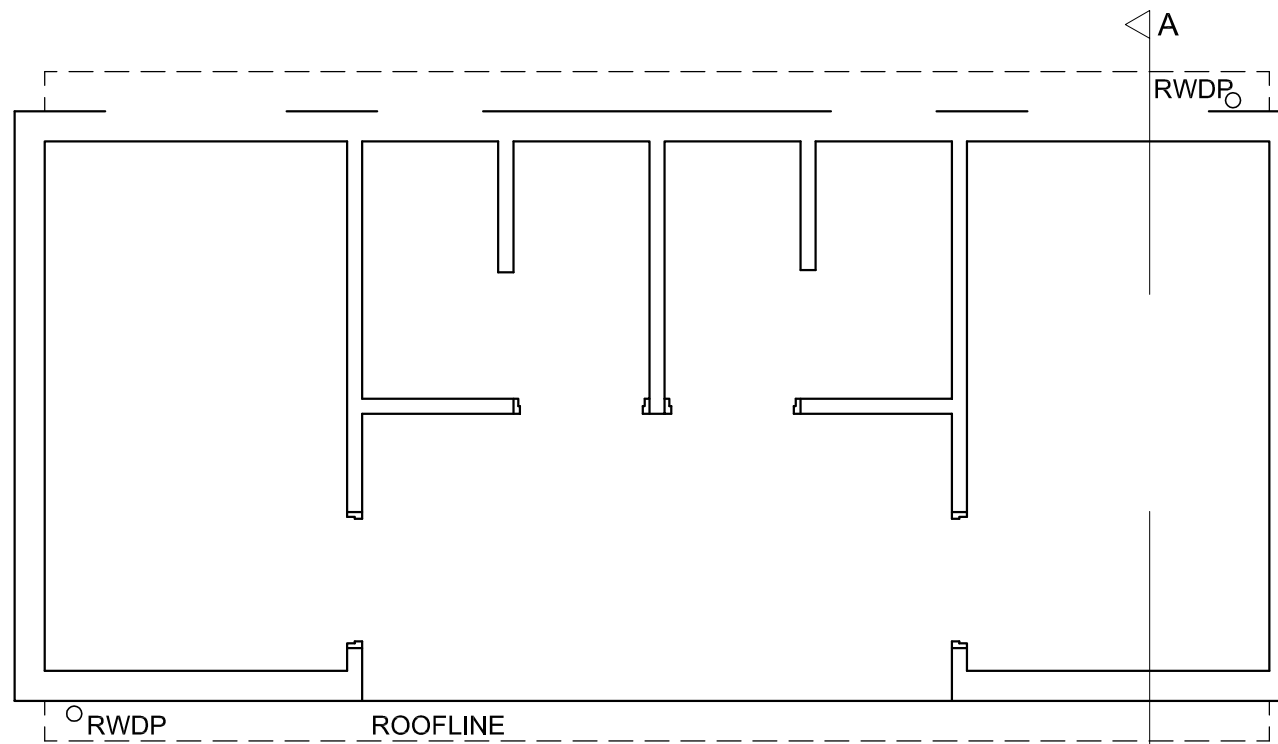

FLOOR PLAN
SCALE 1 : 50

ASSESSMENT CRITERIA					
FLOOR PLAN					
		POSSIBLE	OBTAINED	SIGN	MODERATE
1	LABELS	2			
2	ELECTRICAL	10			
3	FIXTURES	6			
4	DOORS + WINDOWS	14			
5	HATCHING	4			
SUBTOTAL		36			
SOUTH ELEVATION					
1	WALLS + FFL + DOOR + SH	11			
2	ROOF, GUTTER + RWDP	3			
3	LABELS	2			
SUBTOTAL		16			
SECTIONAL ELEVATION					
1	ROOF	15			
2	WALLS + FLOOR + FOUNDATION	13			
3	WINDOW, DOOR + FIXTURES	5			
4	HATCHING	6			
5	LABELS	3			
SUBTOTAL		42			
TOTAL		94			
EXAMINATION NUMBER					
EXAMINATION NUMBER				6	

